



192 Digital I/O™



Copyright

© 2006 Digidesign, a division of Avid Technology, Inc. All rights reserved. This guide may not be duplicated in whole or in part without the express written consent of Digidesign. Avid,

Digidesign, Avid, and Pro Tools are either trademarks or registered trademarks of Avid Technology, Inc. in the US and other countries. All other trademarks contained herein are the property of their respective owners.

Product features, specifications, system requirements, and availability are subject to change without notice.

PN 9106-18598-00 Rev A 1/06

Warning

This product contains chemicals, including lead, known to the State of California to cause cancer and birth defects or other reproductive harm. *Wash hands after handling.*

Communications & Safety Regulation Information

Compliance Statement

The model 192 Digital I/O complies with the following standards regulating interference and EMC:

- FCC Part 15 Class A
- EN55103 – 1, environment E4
- EN55103 – 2, environment E4
- AS/NZS 3548 Class A

Radio and Television Interference

This equipment has been tested and found to comply with the limits for a Class A digital device, pursuant to Part 15 of the FCC Rules.

Communications Statement

This equipment has been tested to comply with the limits for a Class A digital device. Changes or modifications to this 192 Digital I/O not authorized by Digidesign, Inc., could void the Certification and negate your authority to operate the 192 Digital I/O. This 192 Digital I/O was tested for CISPR compliance under conditions that included the use of peripheral devices and shielded cables and connectors between system components. Digidesign recommends the use of shielded cables and connectors between system components to reduce the possibility of causing interference to radios, television sets, and other electronic devices.

Safety Statement

This equipment has been tested to comply with USA and Canadian safety certification in accordance with the specifications of UL Standards; UL1419 and Canadian CSA standard; CSA C22.2 No.1-M90. Digidesign Inc., has been authorized to apply the appropriate UL & CUL mark on its compliant equipment.

Important Safety Instructions

When using electric or electronic equipment, basic precautions should always be followed, including the following:

- Read all instructions before using this equipment.
- To avoid the risk of shock, keep this equipment away from rain water, and other moisture. Do not use this equipment if it is wet.
- The equipment should only be connected to the correct rating power supply as indicated on the 192 Digital I/O.
- Do not attempt to service the equipment. There are no user-serviceable parts inside. Please refer all servicing to authorized Digidesign personnel.
- Any attempt to service the equipment will expose you to a risk of electric shock, and will void the manufacturer's warranty.

Warning!

- Pro Tools|HD audio interfaces need room at their sides to maintain proper air flow and cooling.
- Do not install these units into a rack or other enclosure that doesn't leave room on either side for the unit fans.
- Do not block the sides of the units (where fans are), or disconnect the fan.
- If the units are racked up in a case, remove all lids, doors, or covers before operating the units.
- Failure to do so can result in the units overheating very quickly, which can permanently damage them.

contents

Chapter 1. Introduction to the 192 Digital I/O	1
192 Digital I/O Features	1
What's Included	2
System Requirements	2
Digidesign Registration	2
About this Guide	2
About www.digidesign.com	3
Chapter 2. 192 Digital I/O Overview	5
192 Digital I/O Front Panel	5
192 Digital I/O Rear Panel	7
Installing and Configuring the 192 Digital I/O for Pro Tools HD	10
Appendix A. Card Removal and Replacement	11
Removing an I/O Card	11
Replacing an I/O Card	12
Appendix B. Pinout Diagrams for the DB-25 Connectors	15
AES/EBU DB-25	15
TDIF DB-25	16
Index	17

chapter 1

Introduction to the 192 Digital I/O

The Digidesign 192 Digital I/O 16-channel, all-digital audio interface is for use in a Pro Tools|HD system.

The 192 Digital I/O supports the major digital audio I/O formats (AES/EBU, S/PDIF, ADAT Lightpipe, and TDIF) and sample rates of up to 192 kHz.

192 Digital I/O Features

- 16 discrete channels of digital input and output, with 4-segment LED meters to monitor input and output levels on each channel
- Real-time sample rate conversion (up to 192 kHz) of up to eight different pairs of input formats and sample rates
- Input format can be chosen on a channel-pair basis from the following format types, provided on two factory-installed Digidesign Digital I/O cards:
 - 16 channels of 24-bit AES/EBU I/O at sample rates of up to 96 kHz in single-wire mode; or 8 channels at sample rates of up to 192 kHz in dual-wire mode
 - 16 channels of 24-bit TDIF I/O at sample rates of up to 48 kHz
 - 16 channels of 24-bit Optical (ADAT) I/O at sample rates of up to 48 kHz
- Additional digital I/O options are provided by three sets of enclosure-mounted ports:
 - Two additional channels of 24-bit-capable S/PDIF I/O, supporting sample rates of up to 96 kHz
 - Two additional channels of 24-bit-capable AES/EBU I/O, supporting sample rates of up to 96 kHz
 - Eight additional channels of 24-bit-capable ADAT Optical I/O, at up to 48 kHz sample rates; can be switched to become two channels of optical S/PDIF I/O, supporting sample rates of up to 96 kHz
- External Clock input and output for synchronizing 192 Digital I/O with external 1x Word Clock or 256x (Slave Clock) devices
- Legacy Port for connecting Digidesign-qualified Pro Tools|24 MIX audio interfaces.
- Simultaneous use of multiple Pro Tools|HD audio interfaces to further expand system input and output. For more information see the *Expanded Systems Guide*.

What's Included

- 192 Digital I/O
- AC power cable
- DigiLink cable (1.5ft. [0.46m])
- BNC cable (1.5ft. [0.46m])

System Requirements

The Digidesign 192 Digital I/O requires a Digidesign-qualified Pro Tools|HD system.

Compatibility Information

Digidesign can only assure compatibility and provide support for hardware and software it has tested and approved.

For a list of Digidesign-qualified computers, operating systems, hard drives, and third-party devices, refer to the Digidesign Web site (www.digidesign.com).

Digidesign Registration

Review the enclosed registration information card and follow the instructions on it to quickly register your purchase online. Registering your purchase is the only way you can be eligible to receive complimentary technical support and future upgrade offers. It is one of the most important steps you can take as a new user.

About this Guide

This guide provides a basic overview of the 192 Digital I/O features and functionality.

Complete instructions for connecting and configuring your Pro Tools|HD system are located in the *Pro Tools|HD Getting Started Guide*.

For additional information about using Pro Tools software to route your interface inputs and outputs to Pro Tools inputs and outputs, see the *Pro Tools Reference Guide*.

Conventions Used in This Guide

Digidesign guides use the following conventions to indicate menu choices and key commands:

Convention	Action
File > Save	Choose Save from the File menu
Control+N	While pressing the Control key, press the N key
Control-click	While pressing the Control key, click the mouse button
Right-click (Windows)	Click with the right mouse button

The following symbols are used to highlight important information:



User Tips are helpful hints for getting the most from your system.



Important Notices include information that could affect your data or the performance of your system.



Shortcuts show you useful keyboard or mouse shortcuts.



Cross References point to related sections in other Digidesign guides.

About www.digidesign.com

The Digidesign Web site (www.digidesign.com) is your best online source for information to help you get the most out of your Pro Tools system. The following are just a few of the services and features available.

Registration Register your purchase on-line. See the enclosed registration form for instructions.

Support Contact Digidesign Technical Support or Customer Service; download software updates and the latest online manuals; browse the Compatibility documents for system requirements; search the online Answerbase or join the worldwide Pro Tools community on the Digidesign User Conference.

Training and Education Study on your own using courses available online or find out how you can learn in a classroom setting at a certified Pro Tools training center.

Products and Developers Learn about Digidesign products; download demo software or learn about our Development Partners and their plugins, applications, and hardware.

News and Events Get the latest news from Digidesign or sign up for a Pro Tools demo.

To learn more about these and other resources available from Digidesign, visit the Digidesign Web site (www.digidesign.com).

chapter 2

192 Digital I/O Overview

This chapter describes the front and rear panel features of the 192 Digital I/O.

 See the *Pro Tools|HD Getting Started Guide* for complete system installation and configuration instructions. If you are adding the 192 Digital I/O to an existing system, see the *Expanded Systems Guide*.

192 Digital I/O Front Panel

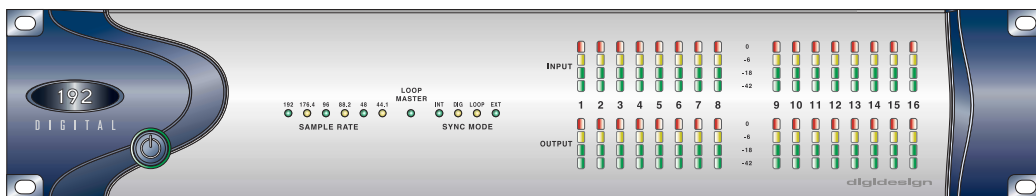

192 Digital I/O front panel

Power Switch and LED Ring

This button turns the 192 Digital I/O on and off. The LED ring around the power button will light green to indicate that the unit has powered up successfully and is connected to an active HD system. If the LED ring is orange, the unit has power, but the computer it is connected to is shut down.

Sample Rate

These LEDs display the current sample rate of the 192 Digital I/O internal crystal oscillator: 44.1 kHz, 48 kHz, 88.2 kHz, 96 kHz, 176.4 kHz, or 192 kHz. The sample rate is set when you create a new session, and can be changed in the Pro Tools Hardware Setup or Playback Engine dialogs if no session is open.

Loop Master LED

The LOOP MASTER LED indicates which Pro Tools|HD audio interface is the master Pro Tools peripheral. Loop Master defaults to the first Pro Tools|HD I/O connected to the “core” Pro Tools|HD card. On Pro Tools|HD (for PCIe) this is the Accel Core card. On Pro Tools|HD (for PCI) this is the HD Core card. Loop Master will always be lit in systems with a single interface.

In expanded systems, only one Pro Tools|HD I/O can be Loop Master at a time. When you change the clock source to an external clock on a particular Pro Tools|HD I/O or a SYNC I/O, that Pro Tools|HD I/O (or SYNC I/O) will automatically become the Loop Master and all other Pro Tools|HD I/Os in the chain will be switched to Loop Slave mode.

Sync Mode LEDs

The SYNC MODE LEDs indicate different clock source modes. Synchronization mode LEDs reflect the Clock Source choice in Pro Tools.

The SYNC MODE LEDs indicate the current clock source.

INT (Internal) This is the 192 Digital I/O standard clock setting. In this mode, the 192 Digital I/O sample clock is generated by its internal crystal oscillator, as determined by the session Sample Rate.

DIG (Digital) Indicates that an external AES/EBU, Optical (ADAT), or S/PDIF device is providing system clock.

LOOP Indicates that the 192 Digital I/O is slaving to another Pro Tools|HD I/O through Loop Sync.

EXT (External) Indicates that 192 Digital I/O is using the EXT CLOCK IN port for system synchronization. External Clock input and output do not have to be at the Word clock rate.

For more information, see the *Pro Tools|HD Getting Started Guide*.

Meters

These four-segment LEDs indicate signal level for each of the sixteen channels. The top row of meters indicates input levels, and the bottom row shows output levels. These meters are calibrated at -42 dB, -18 dB, -6 dB, and 0 dB, respectively.



Note that 0 dB is not to be confused with clipping; use the on-screen meters in Pro Tools to determine whether a signal is clipping.

192 Digital I/O Rear Panel

The 192 Digital I/O has the following rear panel features:

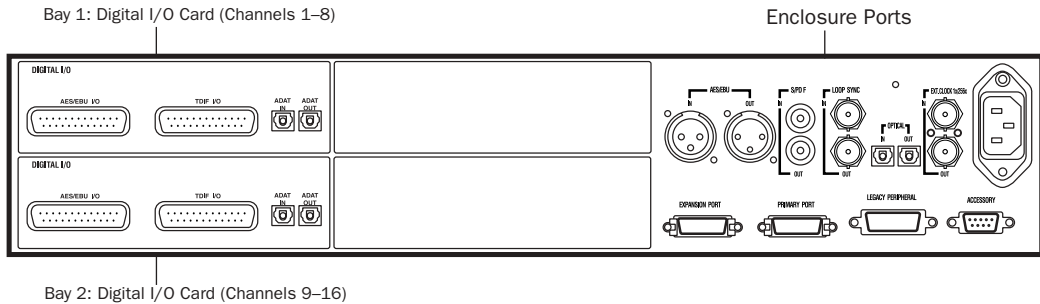

192 I/O rear panel

Inputs and outputs are provided by the two Digital I/O Cards, and the built-in Enclosure ports. The two empty bays (located in the middle of the rear panel) are not expandable.

Digital I/O Cards

The 192 Digital I/O features two Digital I/O cards with identical sets of input and output ports. Each card handles eight of the 16 total available channels of I/O. The top card (Bay 1) handles I/O channels 1–8. The bottom card (Bay 2) handles channels 9–16.

The inputs on the Digital I/O card feature real-time sample rate conversion. For example, you can stream audio with a sample rate of 44.1 kHz into a 96 kHz session.

Input is provided through DB-25 connectors for AES/EBU and TDIF inputs, along with a pair of ADAT optical ports. (For more information, see Appendix B, “Pinout Diagrams for the DB-25 Connectors.”)

The TDIF and ADAT outputs will output up to 48 kHz. The AES/EBU output can output supported sample rates from 44.1 kHz to 192 kHz.

About Real-Time Sample Rate Conversion

Each set of inputs on the Digital I/O cards can stream in at any sample rate and be converted to the current Pro Tools session sample rate via hardware-based real-time sample-rate conversion chips.

Sample rate conversion is selectable on a channel pair basis. When disabled, digital information completely bypasses the sample-rate conversion chips.

Digital Formats

AES/EBU Each card contains DB-25 connectors for eight channels of AES/EBU I/O. Each of the four paired channels of AES/EBU on each card is a balanced three-conductor signal that supports single wire I/O up to 96 kHz and dual wire I/O up to 192 kHz.

For AES/EBU input, each Digital I/O card can accept up to 192 kHz and downsample the information to any other supported sample rate.

Dual-Wire mode uses two pins to transmit a single channel, or four pins to transmit two channels of digital audio. Dual-wire is only supported via the DB-25 AES/EBU connector.

Four channels of AES/EBU I/O are available at 192 kHz per card or eight channels using both AES/EBU connectors.

TDIF Each card contains DB-25 connectors for eight channels of TDIF input and output. This port conforms to standard eight-channel TDIF pinouts. See Appendix B, “Pinout Diagrams for the DB-25 Connectors.”

Optical (ADAT) Each card contains a pair of dedicated, eight-channel 24-bit capable Optical ports for input and output, respectively.

These outputs will only output at sample rates of up to 48 kHz. Unlike the Optical port located on the enclosure, this Optical (ADAT) port is not switchable to Optical S/PDIF.

About Lightpipe-Compatible Devices

Lightpipe is an industry standard, eight-channel optical digital audio connection created by Alesis. Lightpipe is found on many devices, including Optical (ADAT) decks, modular digital multitracks (MDMs), sound cards, A/D or D/A converters, and digital consoles.

Enclosure Connectors

The right half of the back panel of the 192 Digital I/O features a set of non-removable Enclosure connectors.

The connectors feature a two-channel S/PDIF port, two additional channels of AES/EBU I/O and another eight channels of Optical I/O. These ports are hardwired to the 192 Digital I/O chassis and appear on-screen in the Pro Tools pop-up menus as AES/EBU [Encl], SPDIF [Encl], and Optical (ADAT) [Encl]. The reference to the enclosure [Encl] differentiates the chassis-mounted ports from the I/O of the same types on the Digital I/O card.

Also mounted on the enclosure are synchronization ports and connectors for installing the 192 Digital I/O to your Pro Tools|HD system and attaching other audio interfaces.

AES/EBU Digital In and Out

These are an additional pair of balanced, three-conductor XLR connectors that accept and output a stereo, 24-bit AES/EBU digital data stream at sample rates of up to 96 kHz.

Unlike the Digital I/O card AES/EBU ports, the enclosure AES/EBU ports do not support dual-wire mode or provide real-time sample rate conversion.

S/PDIF Digital In and Out

These are an additional pair of unbalanced, two-conductor RCA jacks that accept and output a stereo S/PDIF digital data stream. S/PDIF supports up to 24-bit audio, at sample rates up to 96 kHz. To avoid RF interference during S/PDIF transfers, use 75-ohm coaxial cable.

Optical (ADAT) In and Out

These Optical ports can be configured to function as two channels (stereo) Optical S/PDIF or as a third set of eight channels of Optical (ADAT) input and output.

In Optical S/PDIF mode, these ports support two-channel Optical input and output at sample rates up to 96 kHz. In Optical (ADAT) mode, sample rates above 48 kHz are not supported; unlike Optical (ADAT) ports on the Digital I/O cards, these Optical (ADAT) do not feature real-time sample rate conversion.

LOOP SYNC In and Out

Loop Sync is a dedicated clock loop for synchronizing multiple HD-series interfaces together. Loop Sync uses a word clock signal based on sample rates of either 44.1 kHz or 48 kHz. As sample rate increases in the system, Loop Sync continues to operate at a base rate of 44.1 kHz or 48 kHz, depending upon the higher rate.

The Loop Sync In and Out ports are standard BNC connectors that output a 1x Loop Sync clock signal. Loop Sync should only be used to chain multiple Pro Tools|HD peripherals together.

EXT. CLOCK In and Out

The External Clock I/O ports are standard BNC connectors that receive and output word clock. These ports can be used to synchronize the 192 Digital I/O with any word clock-capable device.

The External Clock In port is configured by your choice for Clock Source in the Hardware Setup dialog. The External Clock Out is configured using the External Clock Out selector in the Hardware Setup dialog.



Because crucial timing data is passed through the Loop Sync and Word Clock ports, you should use high-quality, 75-ohm RG-59 cables for making connections.

AC Power

This connector accepts a standard AC power cable. The 192 Digital I/O is auto power-selecting (100V to 240V) and will automatically work with a standard modular cable to connect to AC power receptacles in any country.

Primary Port

The Primary port is where the 192 Digital I/O is connected to your Accel Core, HD Core, HD Accel or HD Process card using a DigiLink cable. The Primary Port can also be connected to an available Expansion Port on another Pro Tools|HD audio interface used in the system.

The Primary DigiLink port sends and receives 32 channels to and from the Pro Tools|HD cards (or other interface). Channels 17–32 (if active) are passed through to the Expansion port or the Legacy port.

DigiLink Length Specifications

There are five different lengths of DigiLink cables:

- 18" (0.46m), included with each interface
- 12' (3.6m), included with each Pro Tools|HD card
- 25' (7.62m)
- 50' (15.25m), the maximum length supported for 192 kHz sessions (sold separately)
- 100' (30.5m), the maximum length supported by 96 kHz sessions (sold separately)



For more information about DigiLink cables, refer to Digidesign Web site (www.digidesign.com).

Expansion Port

The Expansion port is used to connect an additional Pro Tools|HD I/O to the 192 Digital I/O. This port passes channels 17–32 to the secondary, or expansion, I/O. This port is only available when the 192 Digital I/O is connected to a Pro Tools|HD card (it is not available when the 192 Digital I/O is connected to the Expansion Port on another audio interface). See also “Legacy and Expansion Peripheral Port Limitations” on page 10.

Legacy Port

This port is used to connect MIX-series Digidesign audio interfaces to the 192 Digital I/O. You can connect two eight-channel interfaces (such as the 888|24 or 882|20) or a single sixteen-channel interface (1622 I/O, or 24-bit ADAT Bridge I/O) for expanded input and output options, using their original cables.

When the Legacy port has been activated from within Pro Tools, your MIX-series I/O will appear as channels 17–32 in the Pro Tools mixer.

For more information, see the *Pro Tools|HD Getting Started Guide*.

Legacy and Expansion Peripheral Port Limitations

Because both the Legacy port and the Expansion port use channels 17–32, you can only use one at a time.

The Legacy port is not available in any session in which the sample rate is set for higher than 48 kHz.



*For more information on using Expansion or Legacy audio interfaces, see the *Pro Tools|HD Getting Started Guide*, and the *Expanded Systems Guide*.*

Accessory Port

This port is not supported.

Installing and Configuring the 192 Digital I/O for Pro Tools HD

For complete installation and configuration instructions for the 192 Digital I/O, see the *Pro Tools|HD Getting Started Guide*.

appendix a

Card Removal and Replacement

Removing an I/O Card

In the event of a problem with either of the digital I/O cards in your 192 Digital I/O, you can remove the card and send it to Digidesign for repair. The modular nature of the Pro Tools|HD system allows you to simply return the specific card, instead of the entire 192 Digital I/O.

Pro Tools|HD will continue to function while missing a single card. It will not function if more than one of the factory-installed cards is removed.

⚠ *Before handling any of the cards or internal components of 192 Digital I/O, discharge any static electricity by touching the outer casing of the power supply.*

To remove an I/O card from the 192 Digital I/O:

- 1 Power off and disconnect the 192 Digital I/O from your Pro Tools|HD system.
- 2 Make sure that the equipment is properly grounded.
- 3 Remove the top cover of the 192 Digital I/O by extracting the 16 small Phillips-head screws around the edges of the top cover, and lift it off. Put the screws in a safe place.
- 4 Remove the five screws on the front plate of the card to be removed.
- 5 Gently pull the 50-pin connector off of the edge of the card.

⚠ *When you pull a card out, pay particular attention to keeping components on the surfaces of the card from bumping into any of the internal components or the back panel faceplate on the 192 Digital I/O.*

- 6 Pull the card out by gripping the edges between your thumb and forefinger on each side. Pull straight back, lifting very slightly to avoid contact between components on the underside of the card and the 192 Digital I/O back panel faceplate.



Pulling the card out

- 7 Place the card immediately in an anti-static bag and send it to Digidesign according to instructions from the Customer Support dept.

⚠ *When you pull a card out, pay particular attention to keeping components on the surfaces of the card from bumping into any of the internal components or the back panel faceplate on the 192 Digital I/O.*

Hardware Setup Changes

The Hardware Setup dialog reflects the removal of an I/O card by settings corresponding inputs and outputs to None. The remaining inputs and outputs will function normally.

Replacing an I/O Card

To replace a card:

- 1 Power off and disconnect the 192 Digital I/O from your system.
- 2 Make sure that the 192 Digital I/O is plugged in so that it is grounded.
- 3 Remove the top cover of the 192 Digital I/O by extracting all of the 16 small phillips-head screws around the edges of the top cover, and lifting it off.
- 4 If the card you are replacing is still connected to the 192 Digital I/O, see “Removing an I/O Card” on page 11.
- 5 To discharge any static electricity, touch the power supply casing. It is a good idea to do this often, throughout the process.
- 6 Look into the empty bay to locate the guide rails for the card to slide in on.



Example of an empty bay. Note guide rails along the inside edge



Placing the edge of the card into the guide rails

- 7 Slide the edges of the card into the guide rails on each side of the bay. Push the card all the way in until the card's faceplate is nearly flush with the rear panel of the 96 I/O.
- 8 Screw the card's faceplate onto the rear panel surface of the 192 Digital I/O with the same screws you removed from the empty bay cover.
- 9 Locate the raised ridge in the middle of the 50-pin cable which connects to the 192 Digital I/O chassis. This ridge is only on one side of the connector, and there is a matching groove on only one side of the 50-pin connector on the card.

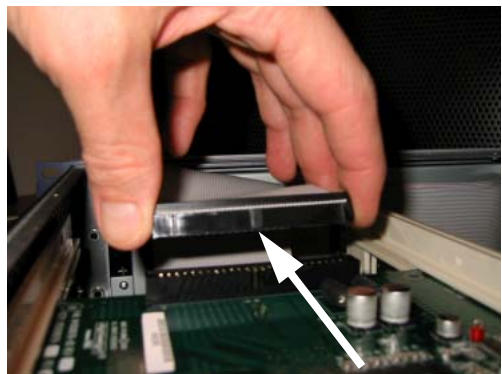

Locating the ridge on the 50-pin cable and the matching groove on the 50-pin connectors on the card

10 Gently push the cable connector into the card's connector. The ridge on the cable connector must be line directly into the groove on the card connector. Be very careful not to bend any of the pins.



Pressing the 50-pin cable connector into the card

11 Place the top cover onto the 192 Digital I/O and replace the screws that you removed with it.

12 Connect the 192 Digital I/O to your Pro Tools|HD system.

13 Press the Power switch.

14 When you power on the unit, the power LED should turn orange.

15 Start up the computer.

16 When you boot up the computer, the ring LEDs around the 192 Digital I/O power should turn from orange to green. (If this does not occur, see "Troubleshooting" on page 13.)

17 Launch Pro Tools.

18 Choose Setup > Hardware. If the new card does not appear in the Hardware Setup dialog, power down, check the seating of the card, and recheck the cables inside the 192 Digital I/O.

Troubleshooting

◆ If the ring of LEDs around the power switch does not turn from orange to green the computer is started, make sure you reconnected the DigiLink cable to the Primary port on the rear of the unit.

◆ If the DigiLink cable is securely fastened and the other end is plugged into a Pro Tools|HD card, you may have inadvertently disconnected another 50-pin cable when installing the card.

Hardware Setup Changes

Whenever a card is removed or replaced, the Hardware Setup I/O routing reverts to original defaults.

appendix b

Pinout Diagrams for the DB-25 Connectors

AES/EBU DB-25

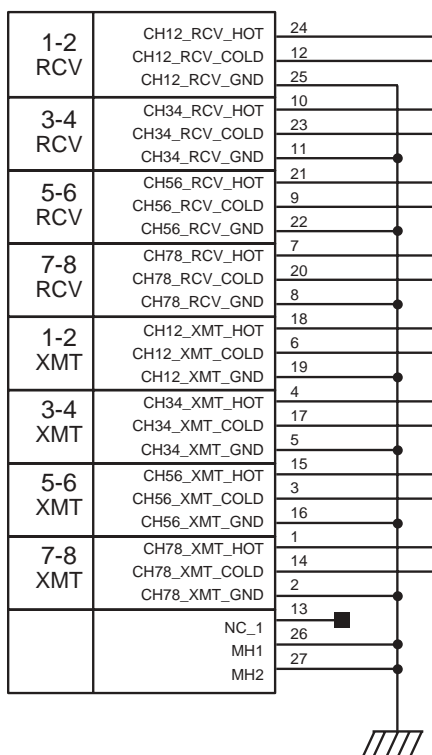

TDIF DB-25

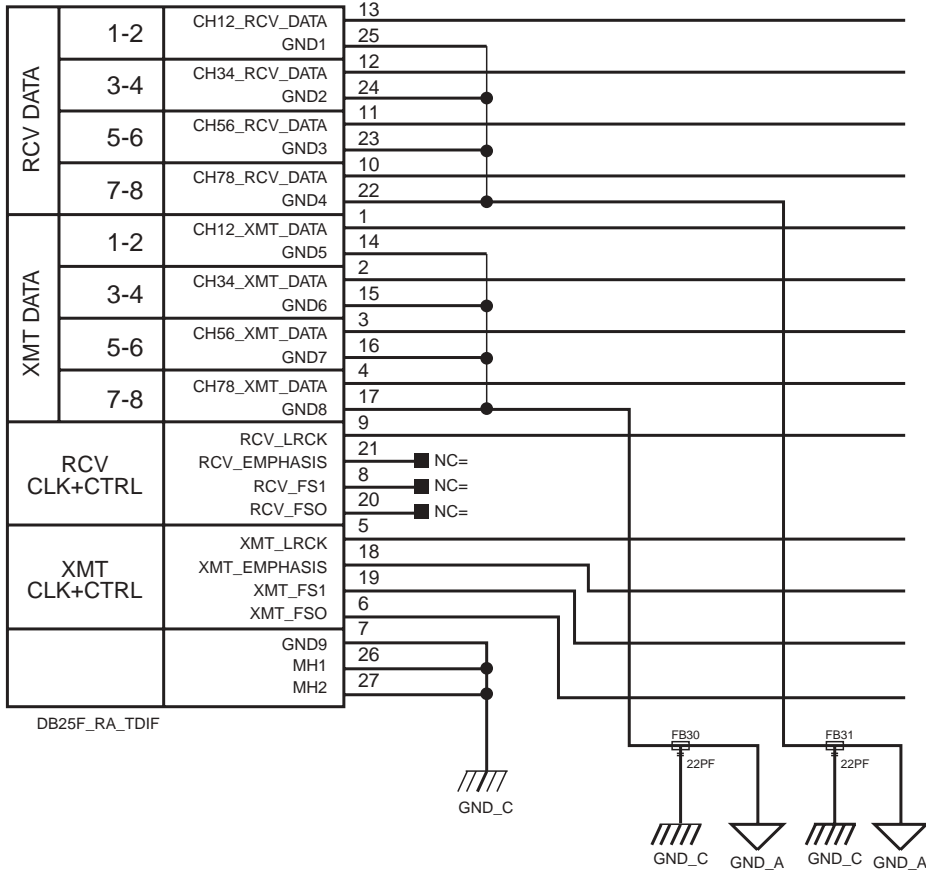

index

Numerics

- 1622 10
- 192 I/O
 - Back Panel 7
 - Front Panel 5
 - Overview 5
- 24-bit ADAT Bridge 10
- 882|20 10
- 888|24 10

A

- AC Power connector 9
- Accessory Port 10
- AES/EBU 6, 8

C

- Clock Source 6, 9

D

- DB–25 connectors 7
- DIG (Digital) 6
- DigiLink
 - expansion 10
 - secondary 10

E

- Enclosure
 - Optical (ADAT) 8
 - Connectors 8
- Expansion
 - DigiLink 10
 - port 10
- External Clock 9
 - I/O ports 9
 - In 6
 - port 6

H

- Hardware Setup 5, 9

I

- INT (Internal) 6

L

- LED ring 5
- Legacy
 - port 10
- Legacy port 10
- Lightpipe
 - Optical port 8
- Loop Master 6
 - mode 6
- Loop Master LED 6
- Loop Sync 6
 - sample rates 9

M

- Meters 6
- MIX-series
 - peripherals 10

O

- Optical
 - I/O 8
- Optical (ADAT)
 - about Lightpipe-compatible devices 8

P

- Pinout Diagrams 15
- Playback Engine 5
- Port Limitations
 - Legacy and Expansion Peripherals 10
- Power Switch
 - and LED ring 5
- Primary
 - DigiLink 9

R

- registration 2
- RF interference 8

S

- S/PDIF 6, 8
- sample clock 6
- Sample Rate 5, 6
 - conversion 7
- secondary I/O 10
- Sync Mode
 - LEDs 6
- synchronization 9

T

- TDIF 8
- TDIF DB-25 Pinout Diagram 16
- Troubleshooting 13

W

- word clock 6, 9



www.digidesign.com

DIGIDESIGN

2001 Junipero Serra Boulevard
Daly City, CA 94014-3886 USA
Tel: 650.731.6300
Fax: 650.731.6399

TECHNICAL SUPPORT (USA)

Tel: 650.731.6100
Fax: 650.731.6384

PRODUCT INFORMATION (USA)

Tel: 650.731.6102
Fax: 800.333.2137

INTERNATIONAL OFFICES

Visit our Digidesign Web site
for contact information