

# Getting Started with Digi 001

**Version 6.1 for LE Systems on Windows XP and Mac OS X**

**Version 5.3.1 for LE Systems on Windows XP**

**Version 5.1.1 for LE Systems on Mac OS 9**

## **Digidesign**

2001 Junipero Serra Boulevard  
Daly City, CA 94014-3886 USA  
tel: 650-731-6300  
fax: 650-731-6399

### **Technical Support (USA)**

tel: 650-731-6100  
fax: 650-731-6384

### **Product Information (USA)**

tel: 650-731-6102  
tel: 800-333-2137

### **International Offices**

Visit the Digidesign Web site  
for contact information

### **Web Site**

[www.digidesign.com](http://www.digidesign.com)



**digidesign**

## Copyright

This guide is copyrighted ©2003 by Digidesign, a division of Avid Technology, Inc. (hereafter "Digidesign"), with all rights reserved. Under copyright laws, this guide may not be duplicated in whole or in part without the written consent of Digidesign.

DIGIDESIGN, AVID and PRO TOOLS are trademarks or registered trademarks of Digidesign and/or Avid Technology, Inc. All other trademarks are the property of their respective owners.

All features and specifications subject to change without notice.

PN 910611593-00 REV A 6/03

### DECLARATION OF CONFORMITY

We Digidesign,

2001 Junipero Serra Boulevard  
Daly City, CA 94014-3886, USA  
650-731-6300

declare under our sole responsibility that the product  
Digi 001

complies with Part 15 of FCC Rules.

Operation is subject to the following two conditions: (1) this device may not cause harmful interference, and (2) this device must accept any interference received, including interference that may cause undesired operation.

NOTE: This equipment has been tested and found to comply with the limits for a Class B digital device, pursuant to Part 15 of the FCC Rules. These limits are designed to provide reasonable protection against harmful interference in a residential installation. This equipment generates, uses, and can radiate radio frequency energy and, if not installed and used in accordance with the instructions, may cause harmful interference to radio communications. However, there is no guarantee that interference will not occur in a particular installation. If this equipment does cause harmful interference to radio or television reception, which can be determined by turning the equipment off and on, the user is encouraged to try and correct the interference by one or more of the following measures:

- Reorient or locate the receiving antenna.
- Increase the separation between the equipment and receiver.
- Connect the equipment into an outlet on a circuit different from that to which the receiver is connected.
- Consult the dealer or an experienced radio/TV technician for help.



Any modifications to the unit, unless expressly approved by Digidesign, could void the user's authority to operate the equipment.

### Canadian Compliance Statement:

This Class B digital apparatus complies with Canadian ICES-003

Cet appareil numérique de la classe B est conforme à la norme NMB-003 du Canada

### Australian Compliance

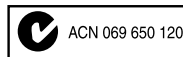

### European Compliance



# contents

<b>Chapter 1. Welcome to Digi 001</b> . . . . .	1
Digi 001 Features . . . . .	1
Pro Tools LE Capabilities . . . . .	2
System Requirements . . . . .	2
Digidesign Registration . . . . .	4
About the Pro Tools Guides . . . . .	4
<b>Chapter 2. Windows Configuration</b> . . . . .	5
Windows System Settings . . . . .	5
Installing Digi 001 Hardware . . . . .	7
Hard Drive Configuration and Maintenance . . . . .	9
Installing Pro Tools LE . . . . .	10
Installing Optional Software for Pro Tools LE . . . . .	11
Launching Pro Tools LE . . . . .	12
Configuring Pro Tools LE System Settings . . . . .	12
<b>Chapter 3. Macintosh Configuration</b> . . . . .	17
Installing Digi 001 Hardware . . . . .	17
Apple System Settings . . . . .	18
Installing Pro Tools LE Software . . . . .	20
Installing OMS . . . . .	21
Installing the Demo Session . . . . .	21
Launching Pro Tools LE . . . . .	21
Configuring Pro Tools LE System Settings . . . . .	22
<b>Chapter 4. Digi 001 Overview</b> . . . . .	29
Digi 001 I/O Box Inputs and Outputs . . . . .	29
Connectors on the Digi 001 PCI Card . . . . .	32

<b>Chapter 5. Connecting Your Studio</b> . . . . .	33
Studio Setup Diagrams . . . . .	34
Monitoring Audio . . . . .	36
Connecting Audio Sources to Digi 001 . . . . .	37
Using External Effects Devices . . . . .	40
Using Monitor Mode . . . . .	41
Connecting a Recorder for Mixdowns . . . . .	42
Connecting a Footswitch . . . . .	44
MIDI Connections . . . . .	44
<b>Chapter 6. Working with Pro Tools LE</b> . . . . .	45
Session Basics . . . . .	45
Transport Controls . . . . .	49
Navigating a Session . . . . .	50
Tracks . . . . .	53
Regions Lists . . . . .	55
Importing Audio . . . . .	55
Basic Recording . . . . .	56
Editing . . . . .	63
Mixing . . . . .	66
Plug-Ins . . . . .	69
Mix Automation . . . . .	69
Final Mixdown . . . . .	70
<b>Appendix A. Windows System Optimizations</b> . . . . .	73
Troubleshooting . . . . .	73
Advanced Settings . . . . .	73
<b>Appendix B. Configuring AMS (Mac OS X Only)</b> . . . . .	75
<b>Appendix C. Digidesign ASIO Driver</b> . . . . .	79
Introduction . . . . .	79
Compatibility . . . . .	79
Installing the ASIO Driver . . . . .	79
Changing ASIO Driver Settings . . . . .	80

<b>Appendix D. Configuring OMS (Mac OS 9 Only)</b> .....	83
<b>Appendix E. Digidesign Control Panel (Mac OS 9 Only)</b> .....	87
<b>Index</b> .....	89



## chapter 1

# Welcome to Digi 001

Welcome to Digi 001, Digidesign's cross-platform Pro Tools system for music, sound design, and multimedia production.

The Digi 001 package includes the following:

- Digi 001 I/O box with connections for audio and MIDI
- Digi 001 PCI Card, which connects to the Digi 001 I/O box and provides 8 channels of Optical I/O
- Installer CD-ROM containing Pro Tools LE software, DigiRack RTAS (Real-Time Audio-Suite) and AudioSuite plug-ins, and electronic PDF guides
- This *Getting Started with Digi 001 Guide*, which includes instructions for installing and configuring Digi 001, and an introduction to Pro Tools LE software
- Rack ears for installing the Digi 001 I/O box in a standard 19-inch rack
- I/O box connector cable, which connects the Digi 001 PCI Card to the Digi 001 I/O box
- Optical cable, which connects the Digi 001 to an ADAT or S/PDIF audio device
- Digidesign Registration card

---

## Digi 001 Features

Digi 001 provides the following:

- 8 analog audio inputs (2 with mic preamps)
- Switchable 48V phantom power on mic preamps
- 8 analog outputs
- 2 analog monitor outputs
- Stereo headphone output with adjustable level control
- Optical input for 8 channels of ADAT input or 2 channels of S/PDIF input
- Optical output for 8 channels of ADAT output or 2 channels of S/PDIF output
- 2 RCA channels of S/PDIF digital I/O
- MIDI in and out, providing up to 16 channels of MIDI I/O
- Footswitch jack for punching in and out while recording.

---

## Pro Tools LE Capabilities

Pro Tools LE software provides the following capabilities with Digi 001:

### Pro Tools LE 6.x

- Record and play back up to 32 mono digital audio tracks, depending on your computer's capabilities
- Sessions can include up to 128 audio tracks (with 32 voiceable tracks maximum), 256 MIDI tracks, 128 Auxiliary Input tracks, and 64 Master Fader tracks.

### Pro Tools LE 5.3.1 (Windows Only)

- Record and play back up to 32 mono digital audio tracks, depending on your computer's capabilities
- Sessions can include up to 32 audio tracks, 128 MIDI tracks, 64 Auxiliary Input tracks, and 64 Master Fader tracks.

### Pro Tools LE 5.1.1

- Record and play back up to 24 mono digital audio tracks, depending on your computer's capabilities
- Sessions can include up to 24 audio tracks, 128 MIDI tracks, 64 Auxiliary Input tracks, and 64 Master Fader tracks.

### All Systems

- 16-bit or 24-bit audio resolution, at sample rates up to 48 kHz
- Nonlinear, random-access editing and mix automation
- Audio processing with up to 5 RTAS plug-ins per track, depending on your computer's capabilities
- Up to 5 inserts and 5 sends per track
- Up to 16 internal mix busses

**A** *Pro Tools LE uses your computer's CPU to mix and process audio tracks (host processing). Computers with faster clock speeds yield higher track counts and more plug-in processing.*

---

## System Requirements

Digi 001 can be used with a Digidesign-qualified Windows or Macintosh computer running Pro Tools LE software.

Digidesign can only assure compatibility and provide support for hardware and software it has tested and approved. For a list of Digidesign-qualified computers, operating systems, hard drives, and third-party devices, refer to the latest compatibility information on the Digidesign Web site ([www.digidesign.com/compato](http://www.digidesign.com/compato)).

### Hard Drive Configuration and Maintenance

It is recommended that you start with a newly initialized audio drive. You should also periodically defragment your audio drive to ensure continued system performance.

For a list of qualified hard drives and SCSI host bus adapters, visit the Digidesign Web site ([www.digidesign.com/compato](http://www.digidesign.com/compato)).

### Avoid Recording to System Drives

Although Pro Tools LE will let you record to your system drive, this is generally not recommended. Recording and playback on system hard drives results in lower track counts and fewer plug-ins.



## Hard Drive Storage Space

Mono audio tracks recorded with 16-bit resolution at 44.1 kHz (CD quality) require approximately 5 MB of hard disk space per minute. The same tracks recorded with 24-bit resolution

require about 7.5 MB per minute. Table 2 lists the required drive space for certain track numbers and track lengths, to help you estimate your hard disk usage.

*Table 2. Required hard drive space for audio tracks*

<b>Number of tracks and length</b>	<b>16-bit at 44.1 kHz</b>	<b>16-bit at 48 kHz</b>	<b>24-bit at 44.1 kHz</b>	<b>24-bit at 48 kHz</b>
1 mono track, 1 minute	5 MB	5.5 MB	7.5 MB	8.2 MB
1 stereo track (or two mono tracks), 5 minutes	50 MB	55 MB	75 MB	83 MB
1 stereo track (or two mono tracks), 60 minutes	600 MB	662 MB	900 MB	991 MB
24 mono tracks, 5 minutes	600 MB	662 MB	900 MB	991 MB
24 mono tracks, 60 minutes	7 GB	7.8 GB	10.5 GB	11.6 GB
32 mono tracks, 5 minutes	800 MB	883 MB	1.2 GB	1.3 GB
32 mono tracks, 60 minutes	9.4 GB	10.4 GB	14 GB	15.4 GB

---

## Digidesign Registration

Make sure to complete and return the registration card included with your Digi 001 system. Registered users will receive periodic software update and upgrade notices. Refer to the registration card for information on technical support.

---

## About the Pro Tools Guides

This *Getting Started with Digi 001 Guide* explains how to install and use Digi 001 to record, edit, and mix audio and MIDI tracks in Pro Tools LE. For additional information, see the following online guides:

- *Pro Tools Reference Guide* explains Pro Tools LE software in detail.
- *DigiRack Plug-Ins Guide* explains how to use the RTAS and AudioSuite plug-ins included with Pro Tools LE.
- *MIDI Control Surfaces Guide* covers the use of MIDI control surfaces (such as MotorMix from CM Labs) with Pro Tools LE.
- *Keyboard Shortcuts* (Macintosh and Windows), lists keyboard shortcuts for Pro Tools LE.

PDF versions of the Pro Tools guides are installed automatically with Pro Tools LE, and are accessible from the Pro Tools menu (Mac OS X) or the Pro Tools Help menu (Windows or Mac OS 9). To view or print the PDF guides, you can install Acrobat Reader (included on the Pro Tools LE Installer CD-ROM).

 *Printed copies of the Pro Tools LE Manual set (including the Pro Tools Reference Guide) can be purchased separately from the DigiStore ([www.digidesign.com](http://www.digidesign.com)).*

## Conventions Used in This Guide

Digidesign guides use the following conventions to indicate menu choices and key commands:

Convention	Action
File > Save Session	Choose Save Session from the File menu
Control+N	While pressing the Control key, press the N key
Control-click	While pressing the Control key, click the mouse button
Right-click (Windows)	Click with the right mouse button

The following symbols are used to highlight important information:

 *User Tips are helpful hints for getting the most from your system.*

 *Important Notices include information that could affect your data or the performance of your system.*

 *Shortcuts show you useful keyboard or mouse shortcuts.*

 *Cross References point to related sections in other Digidesign guides.*

## chapter 2

# Windows Configuration

Installation of the Digi 001 on a Windows computer includes the following steps:

- 1 Configuring Windows system settings (See “Windows System Settings” on page 5.)
- 2 Installing Digi 001 hardware in your computer (See “Installing Digi 001 Hardware” on page 7.)
- 3 Installing Pro Tools LE software (See “Hard Drive Configuration and Maintenance” on page 9.)
- 4 Restarting your computer
- 5 Configuring your system (See “Configuring Pro Tools LE System Settings” on page 12.)
- 6 Making audio connections to Digi 001 (See Chapter 5, “Connecting Your Studio” for details.)

---

## Windows System Settings

Configure your Windows system settings, as follows:

**Required Settings** These instructions must be followed before installing Pro Tools.

**Recommended Settings** These instructions should be followed to optimize your system’s capabilities, or to let older computers run Pro Tools LE.

**▲** *If problems occur after configuring all required and suggested settings, see Appendix A, “Windows System Optimizations” for information on troubleshooting and configuring advanced settings.*

## Required Settings

To ensure optimum performance with Pro Tools LE, configure the following Control Panel settings for your version of Windows XP.

### Disable Hyper-Threading

For Pentium IV computers with Hyper-Threading, disable Hyper-Threading in the BIOS.

### Enable DMA

Enabling your computer’s DMA (Direct Memory Access) frees up CPU bandwidth so your computer can do other Pro Tools tasks.

In most cases the DMA option will already be set correctly, as Windows XP detects and activates DMA mode by default.

### **Enable DMA for any IDE hard drives:**

- 1 Right-click My Computer and choose Manage.
- 2 In Classic view, choose Start > Control Panel > System > Hardware.  
– or –  
In Category view, choose Start > Control panel > Performance and Maintenance > System > Hardware.
- 3 Under System Tools, choose Device Manager.
- 4 In the Device Manager window, double-click IDE ATA/ATAPI controllers, then double-click the Primary IDE Channel for your IDE hard drive.
- 5 Click the Advanced Settings tab.
- 6 For each device, set the Transfer Mode to “DMA if available,” and click OK.

In most cases, this will already be set correctly as Windows XP will detect and activate DMA mode by default.

- 7 Repeat steps 4–6 for any additional IDE Channels.
- 8 Close the Computer Management window.

### **Disable Virus Protection Software**

Avoid running virus protection software while using Pro Tools, since it adversely affects system performance (as do all background processes). If you are using virus protection software, you must turn it off or remove it and restart your computer.

### **Disable System Standby and Power Management**

When using Pro Tools, the Windows System Standby power scheme must be set to Always On. This helps prevent long record or playback passes from stopping due to system resources powering down.

#### **To configure Windows Power Management:**

- 1 Choose Start > Control Panel.
- 2 In Classic View, double-click the Power Options Control Panel, then click the Power Schemes tab.  
– or –  
In Category view, click Performance and Maintenance, then click Power Options, then click the Power Scheme tab.
- 3 From the Power Schemes pop-up menu, select Always On.
- 4 Click OK.

This sets System Standby, System Hibernate, and “Turn off hard disks” to Never.

### **Disable ClearType Font Smoothing**

When using Pro Tools, the Effects “Clear Type” setting must be disabled.

#### **To disable ClearType font smoothing:**

- 1 Choose Start > Control Panel.
- 2 In Classic view, double-click Display.  
– or –

In Category view, click Appearance and Themes, then click Display.

- 3 Click the Appearance tab.
- 4 Click Effects.

- 5 Deselect “Use the following methods to smooth edges of screen fonts.”
- 6 Click OK to save your settings and close the Effects dialog.
- 7 Click OK.

## Completing Windows System Settings

 *When finished updating required Windows system settings, power down your computer.*

## Recommended Configuration

Pro Tools LE can also be affected by other software and hardware drivers installed on your computer. For best possible performance, it is recommended (but not required) that you:

- Avoid running other Windows programs at the same time as Pro Tools LE.
- Turn off any software utilities that run in the background, such as Windows Messenger, calendars, and disk maintenance programs.
- Turn off any nonessential USB devices while using Pro Tools.
- If your video display card supports it, enable Bus Mastering in the manufacturer’s Control Panel.
- Disable any networking cards (other than any 1394 “FireWire” card that you might use to connect an external drive to your system).

 *For information on disabling networking cards, see “Disabling Network Cards” on page 73.*

---

## Installing Digi 001 Hardware

Before installing Pro Tools LE software, install the Digi 001 PCI Card and connect the Digi 001 I/O Box.

### Disabling Driver Signing Warnings

Before you install your Digi 001 PCI card, temporarily disable the Driver Signing warning option.

**To disable the warning option:**

- 1 Open the System Control Panel.
- 2 Click the Hardware tab.
- 3 Click the Driver Signing button.
- 4 Select “Ignore—Install the software anyway and don’t ask for my approval.”
- 5 Click OK twice.
- 6 Shut down and turn off your computer.
- 7 Proceed to install your Digi 001 PCI card.

## Installing the Digi 001 PCI Card

**⚠** *Your computer must be off when you install or remove PCI cards.*

**To install the Digi 001 PCI card in a Windows computer:**

**1** Turn off your computer. Leave it plugged in so that it is grounded, or use an alternate method of grounding according to your computer manufacturer's instructions.

**2** Open the computer case. If necessary, refer to the manufacturer's instructions for details.

**3** Remove the rear slot cover and screw or clamp of any available PCI expansion slot.

**⚠** *Before handling the Digi 001 PCI card, discharge static electricity from your clothes or body by touching a grounded metal surface, such as the power supply case inside your computer.*

**4** Remove the Digi 001 card from its anti-static bag.

**5** Hold the card gently by the top edges, and line up its PCI connector with the PCI slot inside the computer.

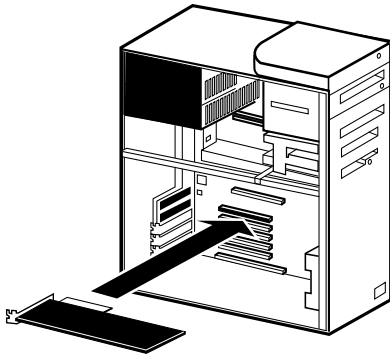

*PCI card installation for a Windows PC*

**6** When the connector and slot are aligned, press the card into the slot using firm, even pressure. The card should click into place. Secure the card in place with the screw or clamp you removed earlier. Make sure the card's audio connectors are accessible through the rear slot of the computer.

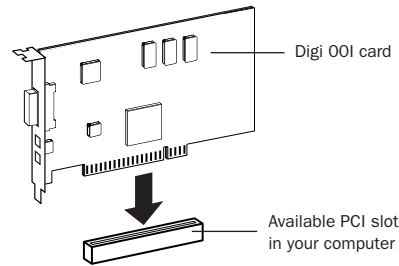

*PCI card installation*

**7** Close the computer case.

## Connecting the Digi 001 I/O Box

**⚠** *Your computer must be off when you connect or disconnect the I/O Box.*

**To connect the Digi 001 I/O Box:**

**1** Locate the connector cable with the wide ends that came with your Digi 001.

**2** Align a cable end with the connector on the Digi 001 PCI Card, and insert the cable into the connector until it clicks into place.

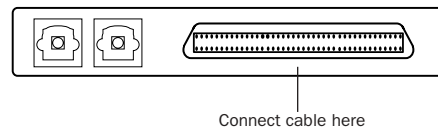

*Digi 001 PCI Card (outside computer view) showing cable connector*

3 Align the other cable end with the Computer connector on the Digi 001 I/O Box, and insert the cable into the connector until it clicks into place.

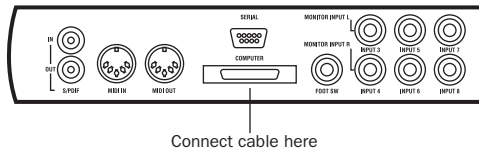

Digi 001 I/O Box, back view showing cable connector

## Hard Drive Configuration and Maintenance

### Formatting an Audio Drive

On Windows, it is recommended that you start with newly formatted drives dedicated for audio. For optimum performance, audio drives should be formatted with the FAT32 or NTFS file system.

#### To format and configure an audio drive:

- 1 Right-click My Computer and choose Manage.
- 2 Under Storage, choose Disk Management.
- 3 In the Disk Management window, right-click the hard drive you will use for audio and choose Format.
- 4 For optimal disk performance, select 32K from the Allocation unit size pull-down. This increases how efficiently audio data is written to and read from the drive.
- 5 Make sure the Quick Format option is deselected, then click Start, and follow the on-screen instructions.

 *Pro Tools only supports Basic drive Types.*

6 When formatting is complete, close the Format window.

### Audio Drives and Disk Cleanup

The process of recording, editing, and deleting tracks and sessions can quickly decrease overall drive performance. It is suggested that you regularly use Disk Cleanup (or an equivalent utility) to assess the condition of drives and, if necessary, delete temporary files and other unused data.

#### To use Disk Cleanup:

- 1 Choose Start > Control Panels.
- 2 In Classic view, double-click Administrative Tools.

– or –

In Category View, click Performance and Maintenance, then click Administrative Tools.

3 Select Computer Management, then select Storage.

4 Choose Disk Management.

5 Select the desired volume in the list, then choose File > Options.

Disk Cleanup determines how performance is being affected by drive condition, and lets you review and delete temporary and other unnecessary files from the selected volume. For more information on using Disk Cleanup, see your Windows XP documentation.

### Defragmenting an Audio Drive

Periodically *defragment* audio drives to maintain system performance.

#### To defragment an audio drive:

- 1 Right-click My Computer and choose Manage.

- 2 Under Storage, choose Disk Defragmenter.
- 3 In the Disk Defragmenter window, choose the drive you want to defragment
- 4 Click the Defragment button and follow the on-screen instructions.
- 5 When defragmenting is complete, close the Computer Management Window.

### **Avoid Recording to System Drives**

Although Pro Tools will let you record to your system drive, this is generally not recommended. Recording and playback on system hard drives results in lower track counts and fewer plug-ins. You should record to system drives only when necessary (for example, if your computer system has just one hard drive)

---

## **Installing Pro Tools LE**

### **To install Pro Tools LE on Windows:**

- 1 Make sure you have configured all the required Windows system settings, and rebooted your computer. See “Windows System Settings” on page 5 for more information.
- 2 Start Windows, logging in with Administrator privileges. If you do not have Administrator privileges or do not know how to set them up, see your Windows User’s Guide.
- 3 Wait for the Found New Hardware Wizard dialog to appear and leave it open (do not press Next).
- 4 Insert the Pro Tools Installer CD-ROM for Windows in your CD-ROM drive. Locate and open the Pro Tools Installer folder, and double-click the Setup icon.
- 5 Click Next to begin installation.

- 6 Select the components you want to install and click Next.

 *If you get a warning dialog about the driver not passing Windows Logo testing, click Continue Anyway.*

- 7 Wait for the installer to finish installing all software components, drivers, and PACE System files before proceeding to the next step.
- 8 Click Quit when prompted to install QuickTime (you will install QuickTime later).
- 9 Restart your computer.

## **Installing QuickTime**

QuickTime 5 or later is required for video playback with Pro Tools LE if you plan to include movie files in your sessions. Installing the latest version of QuickTime for Windows is highly recommended (available from [www.apple.com](http://www.apple.com)). Be sure to install the “Recommended” install of QuickTime or Pro Tools will not handle QuickTime video correctly.

### **To install QuickTime:**

- 1 Locate the QuickTime Installer on your Pro Tools LE Installer CD-ROM (located in the Additional Files folder). Follow the on-screen instructions to complete the QuickTime installation process.
- 2 When installation is complete, click Finish to restart your computer. See “Installing Optional Software for Pro Tools LE” on page 11.

 *If your computer does not start up after installing QuickTime, use Add/Remove Programs to remove Pro Tools LE and QuickTime, then repeat the installation process in “Installing Pro Tools LE” on page 10.*



---

## Installing Optional Software for Pro Tools LE

Your Pro Tools Installer CD-ROM includes several software options (as available for your system).

### Installing Digidesign ASIO Driver

The Digidesign ASIO (Audio Sound Input Output) Driver is a multichannel, multimedia sound driver that lets third-party audio applications record and play back through channels 1–2 of Digi 001. The Digidesign ASIO Driver is *not* required to use Pro Tools LE with Digi 001.

 For information on installing, using, and removing the Digidesign ASIO Driver, see Appendix C, “Digidesign ASIO Driver”.

### Installing the Demo Session

The Pro Tools LE Installer CD includes a demo session that you can use to verify that your system is working.

 Before installing the demo session to your audio drive, make sure the drive is configured as described in “Formatting an Audio Drive” on page 9.

#### To install the demo session:

- 1 Insert the Pro Tools LE Installer CD in your CD-ROM drive. Locate and double-click Setup.exe, in D (CD-ROM drive):\Additional Files\Pro Tools LE Demo Session Installer.
- 2 Set the install location to your audio drive and click Install.
- 3 When installation is complete, click OK.

## Installing MacOpener

With MacOpener you can open and transfer Pro Tools sessions created on HFS and HFS Plus-formatted hard drives (Macintosh) to NTFS or FAT32-formatted hard drives (Windows).

 On Windows-based Pro Tools systems, avoid recording or playing audio on hard drives formatted for Macintosh (the HFS or HFS Plus file system). Use the Save Session Copy In command in Pro Tools to copy the session material to a Windows audio drive formatted using NTFS or FAT32.

To share Pro Tools sessions between Macintosh and Windows system, select the “Enforce Mac/PC Compatibility” option when creating the session, or when saving a session copy.

 While SDII files can be exported or converted on import, they cannot be used within Pro Tools sessions on Windows.

#### To install and configure the MacOpener demo included with Pro Tools:

- 1 Insert the Pro Tools Installer CD into your CD-ROM drive.
- 2 Locate and double-click the MacOpener installer file in the MacOpener Demo folder located at D (CD-ROM drive):\Additional Files\MacOpener Demo Installer. Follow the on-screen instructions to install the MacOpener. After installation is complete, restart your computer.
- 3 Choose Start > Programs > MacOpener > MacOpener Driver Preferences.
- 4 Verify that the MacOpener Driver is enabled. Under Driver Settings, select “Enable MacOpener Driver.”
- 5 Under Extension Mapping, select “Do not add the PC extension to the Mac file name.”

6 Click OK to quit the MacOpener Driver Preferences.

7 Choose Start > Programs > MacOpener > Mac Lic.exe. When installation is complete, close the installer.

 All formatting and maintenance of HFS/HFS+ drives should be carried out when the drive is connected to a Macintosh.

 For more information about MacOpener and its performance limitations, see the Pro Tools Reference Guide.

## Removing Pro Tools LE

If you need to remove Pro Tools LE from your computer use the Add or Remove Programs command.

### To remove Pro Tools LE:

1 Choose Start > Control Panel.  
2 In Classic view, double-click the Add or Remove Programs icon.

– or –

In Category view, click Administrative Tools, then click Add or Remove Programs.

3 From the Currently installed programs list, select Digidesign Pro Tools LE.  
4 Click the Change/Remove button.  
5 Select Remove, then click Next.  
6 Click OK to remove Pro Tools LE.

---

## Launching Pro Tools LE

When launching Pro Tools LE the first time, you are prompted to enter an authorization code to validate your software.

With new Digi 001 systems, the authorization code is located on the inside cover of the *Getting Started with Digi 001 Guide*. With software upgrades, the authorization code is located on the inside cover of the *Upgrading Guide*.

### To authorize Pro Tools LE software:

1 Double-click the Pro Tools LE shortcut on your desktop (or the application in the Pro Tools folder inside the Digidesign folder).  
2 Enter the authorization code in the dialog when prompted (making sure to type it exactly as printed, and observing any spaces and capitalization) then click Validate.

---

## Configuring Pro Tools LE System Settings

You can adjust the performance of your system by changing system settings that affect its capacity for processing, playback, and recording.

In most cases, the default settings for your system provide optimum performance, but you may want to adjust them to accommodate large or processing-intensive Pro Tools sessions.

## Hardware Buffer Size

The Hardware Buffer Size (H/W Buffer Size) controls the size of the hardware cache used to handle host processing tasks such as Real-Time AudioSuite (RTAS) plug-ins.

- ◆ Lower Hardware Buffer Size settings reduce monitoring latency, and are useful when you are recording live input.
- ◆ Higher Hardware Buffer Size settings allow for more audio processing and effects, and are useful when you are mixing and using more RTAS plug-ins.

**⚠** *In addition to causing slower screen response and monitoring latency, higher Hardware Buffer Size settings can affect the accuracy of plug-in automation, mute data, and timing for MIDI tracks.*

### To change the Hardware Buffer Size:

- 1 Choose Setups > Playback Engine.

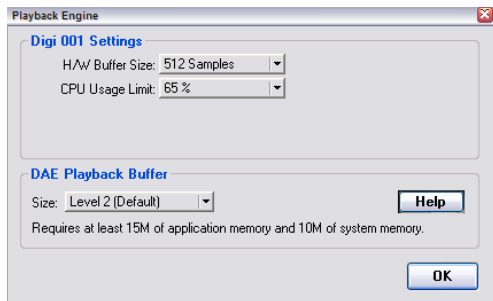

*Playback Engine dialog for Digi 001*

- 2 From the H/W Buffer Size pop-up menu, select the audio buffer size, in samples.
- 3 Click OK.

## CPU Usage Limit

The CPU Usage Limit controls the percentage of CPU resources allocated to Pro Tools host processing tasks.

- ◆ Lower CPU Usage Limit settings limit the effect of Pro Tools processing on other CPU-intensive tasks, such as screen redraws, and are useful when you are experiencing slow system response, or when running other applications at the same time as Pro Tools.
- ◆ Higher CPU Usage Limit settings allocate more processing power to Pro Tools, and are useful for playing back large sessions or using more real-time plug-ins.

**⚠** *Increasing the CPU Usage Limit may slow down screen responses on slower computers.*

- ◆ The maximum CPU Usage Limit is 85 percent for single-processor computers, and 99 percent for multi-processor computers. (The 99 percent setting dedicates one entire processor to Pro Tools.)

## DAE Playback Buffer Size

The DAE Playback Buffer Size determines the amount of memory DAE uses to manage disk buffers, which affects system performance.

- ◆ Lower DAE Playback Buffer Size settings can improve playback and recording initiation speed. However, a lower setting can make it difficult for slower hard drives to play or record tracks reliably.
- ◆ Higher DAE Playback Buffer Size settings can allow for a higher density of edits in a session. However, a higher setting can cause a time lag to occur before playback or recording begins. It can also cause a time lag to occur when you are editing during playback.

### To change the DAE Playback Buffer Size:

- 1 Choose Setups > Playback Engine.
- 2 From the DAE Playback Buffer pop-up menu, select a buffer size.
- 3 Click OK.

## Pro Tools Hardware Settings

Using the Hardware Setup dialog, you can select the default sample rate, clock source, digital input format, and input gain settings for your Digi 001 system.

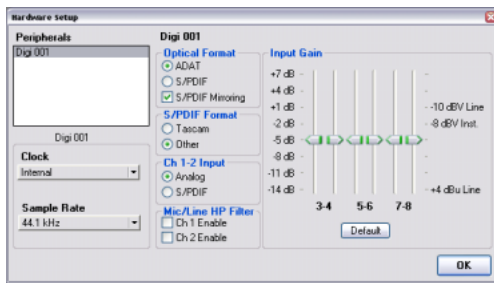

Hardware Setup dialog for Digi 001

### Default Sample Rate

The Sample Rate setting appears as the default sample rate when you create a new session. (This setting is available in the Hardware Setup dialog only when no session is open.)

 You can change the sample rate when creating a new Pro Tools session by selecting a different sample rate in the New Session dialog. (Refer to the Pro Tools Reference Guide for details.)

### To change the default Sample Rate:

- 1 Make sure that no Pro Tools session is open.
- 2 Choose Setups > Hardware Setup.
- 3 Choose the sample rate from the Sample Rate pop-up menu.

- 4 Click OK.

## Clock Source

Using the Hardware Setup dialog, you can select the clock source for the system.

**Internal** If you are recording an analog signal directly into Digi 001, you will usually use the Pro Tools Internal clock source. The Clock Source automatically changes to Internal when you change the Ch. 1–2 Input to Analog.

**SPDIF/RCA** If you are transferring material into Pro Tools from an external digital device, you will usually synchronize Pro Tools to that digital device. The Clock Source automatically changes to SPDIF/RCA when you change the Ch. 1–2 Input to SPDIF/RCA.

### To select the Clock Source:

- 1 Choose Setups > Hardware Setup.
- 2 Choose the clock source from the Clock pop-up menu.
- 3 Click OK.

 Your digital input device must be connected and powered on for Pro Tools to synchronize to it. If your input device is not powered on, leave the Clock Source set to Internal.

## Digital I/O Format

Pro Tools LE provides controls for setting the digital I/O for mat and S/PDIF compatibility of Digi 001.

### To change the digital I/O format settings:

- 1 Choose Setups > Hardware Setup.

2 Set the controls for the following options:

**Optical Format** Select ADAT or S/PDIF, depending on whether you are using the Optical inputs and outputs for ADAT or S/PDIF format.

**S/PDIF Mirroring** When this option is enabled, the S/PDIF (RCA) outputs automatically mirror the audio that is sent to analog outputs 1 and 2.

**S/PDIF Format** Set the S/PDIF I/O format to DA-30 if you are using a Tascam DA-30 DAT recorder. Otherwise, select Other.

**Ch 1–2 Input** Sets the input for Channel 1–2 to Analog or S/PDIF.

3 Click OK to close the Hardware Setup dialog.

### Input Gain and High Pass Filter

You can adjust the input gain on input channels 3–8, and insert a high-pass filter on input channels 1–2.

#### To change the input gain and filter settings:

1 Choose Setups > Hardware Setup.

2 Set the controls for the following options:

**Input Gain** Adjust the gain on analog channels 3–8 by dragging the Input Gain sliders.

**Mic/Line HP Filter** Enable a high-pass filter (set at 60 Hz) on Channels 1 and 2 for filtering out low-end rumble from a noisy recording environment, microphone handling, or AC noise.

3 Click OK to close the Hardware Setup dialog.

### Recording a Digital Source

If you are recording from an optical or S/PDIF device, you will need to choose Clock Source settings. In most cases, you will synchronize the Pro Tools clock to the external device.

#### To configure Pro Tools LE for a digital source:

1 Connect an ADAT or S/PDIF format optical device to the Optical In on the Digi 001 PCI Card, or connect an RCA S/PDIF device to the RCA connectors on the back of the Digi 001 I/O Box.

**A** *You can only use one pair of S/PDIF inputs (either RCA or optical) at a time.*

2 Choose Setups > Hardware Setup.

3 From the Clock Source pop-up menu, select Optical or S/PDIF (RCA), depending on where you connected your digital device.

**A** *Your digital input device must be connected and powered on for Pro Tools to synchronize to it. If your input device is not powered on, leave the Clock Source set to Internal.*

4 If you are using the S/PDIF (RCA) input, select Tascam or Other depending on whether or not you are using a Tascam DA-30.

– or –

If using the optical input on the Digi 001 PCI Card, select the correct Optical Format (ADAT or S/PDIF).

### Configuring I/O Setup

Using the I/O Setup dialog, you can label Pro Tools LE input, output, insert, and bus *signal paths*. The I/O Setup dialog provides a graphical representation of the inputs, outputs, and signal routing of the Digi 001.

Pro Tools LE has default I/O Setup settings that will get you started. Use the I/O Setup dialog only if you want to rename the default I/O paths.



## chapter 3

# Macintosh Configuration

Installation of the Digi 001 on a Macintosh includes the following steps:

- 1 Installing Digi 001 hardware in your computer (See “Installing Digi 001 Hardware” on page 17.)
- 2 Configuring Apple System Software settings (See “Apple System Settings” on page 18.)
- 3 Installing Pro Tools LE software (See “Installing Pro Tools LE Software” on page 20.)
- 4 Restarting your computer
- 5 Configuring your system (See “Configuring Pro Tools LE System Settings” on page 22.)
- 6 Making audio connections to Digi 001 (See Chapter 5, “Connecting Your Studio” for details.)

---

## Installing Digi 001 Hardware

Before installing Pro Tools LE software, you first install the Digi 001 PCI Card and connect the Digi 001 I/O Box.

### Installing the Digi 001 PCI Card

- ⚠** *Your computer must be off when you install or remove PCI cards.*

**To install the Digi 001 PCI Card in a Macintosh:**

- 1 Turn off your computer. Leave it plugged in so that it is grounded.
- 2 Open the computer case. If necessary, refer to the manufacturer’s instructions for details.
- 3 Remove the rear slot cover and screw of any available PCI expansion slot.

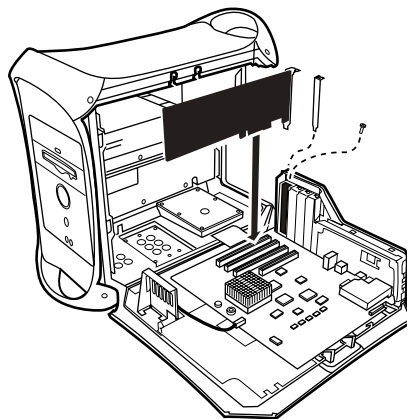

PCI card installation for Macintosh

- ⚠** *Before handling the Digi 001 PCI card, discharge static electricity from your clothes or body by touching a grounded metal surface, such as the power supply case inside your computer.*

- 4 Remove the Digi 001 PCI Card from its anti-static bag.

5 Hold the card gently by the top edges, and line up its PCI connector with the PCI slot inside the computer.

6 When the connector and slot are aligned, press the card into the slot using firm, even pressure. The card should click into place. Secure the card with the slot access port screw you removed earlier. Make sure the card's audio connectors are accessible through the rear slot of the computer.

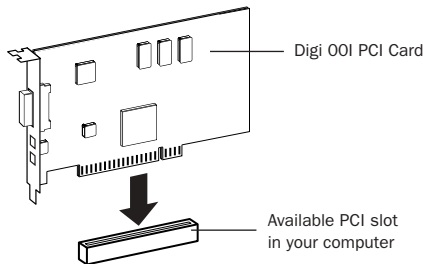

PCI card installation

7 Close the computer case.

## Connecting the Digi 001 I/O Box

**⚠** Your computer must be off when you connect or disconnect the I/O Box.

To connect the Digi 001 I/O Box:

1 Locate the connector cable with the wide ends that came with your Digi 001.

2 Align a cable end with the connector on the Digi 001 PCI Card, and insert the cable into the connector until it clicks into place.

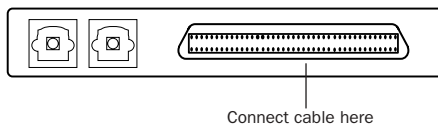

Digi 001 PCI Card (outside computer view) showing cable connector

3 Align the other cable end with the Computer connector on the Digi 001 I/O Box, and insert the cable into the connector until it clicks into place.

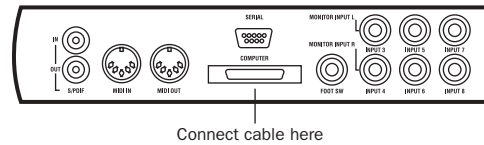

Digi 001 I/O Box, back view showing cable connector

4 Turn on your computer.

---

## Apple System Settings

To ensure optimum performance with Pro Tools LE, configure the following settings for your version of Mac OS before you install Pro Tools software.

## System Settings for Mac OS X

The following settings ensure optimum performance and compatibility for systems running Mac OS X.

**⚠** Do not use the Mac OS X automatic Software Update feature, as it may upgrade your system to a version of Mac OS that has not yet been qualified for Pro Tools. For details on qualified versions of Mac OS, refer to the latest compatibility information on the Digidesign Web site ([www.digidesign.com](http://www.digidesign.com)).

To configure Mac OS X for Pro Tools LE:

1 Make sure you are logged in as an Administrator, in the account where you want to install Pro Tools. For details on Administrator privileges in Mac OS X, refer to your Mac OS X documentation.



2 Choose System Preferences from the Apple Menu and click Energy Saver.

3 Click the Sleep tab and turn off the Energy Saver feature by setting the sleep feature to Never.

4 Return to the System Preferences and click Software Update.

5 Deselect “Automatically check for updates when you have a network connection.”

6 Close the Software Update dialog box.

7 Proceed to “Installing Pro Tools on Mac OS X” on page 20.

## System Settings for Mac OS 9

The following settings ensure optimum performance and compatibility for systems running Mac OS 9.

### To configure Mac OS 9 for Pro Tools LE:

1 In the Memory Control Panel, do the following:

- Set Virtual Memory to Off.
- Set the RAM Disk to Off.
- Set the Disk Cache to a Custom Setting of 512K.

2 In the Energy Saver Control Panel, set the “inactive” time to Never.

3 In the Appearance Control Panel, do the following:

- Click the Fonts tab and set the Large System Font to Chicago. In addition, deselect “Smooth all fonts on screen.”
- Click the Sound tab and select None from the Sound Track pop-up menu.

4 In the Extensions Manager Control Panel, choose the “Mac OS 9.2.2 Base” set from the Selected Set pop-up menu.

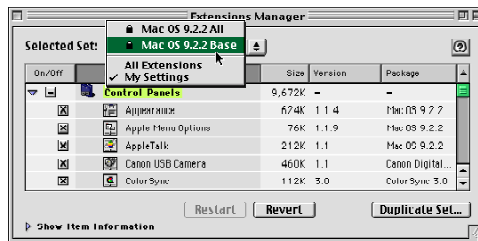

### Extensions Manager Control Panel

5 Click Duplicate Set, name the new set “Pro Tools,” and click OK.

6 Click Restart to restart your computer.

💡 After you install Pro Tools, a number of Digidesign extensions will be added to the new “Pro Tools” Extension Set. Be sure this “Pro Tools” Extension Set is activated whenever you use Pro Tools.

7 Proceed to “Installing Pro Tools on Mac OS 9” on page 20.

---

## Installing Pro Tools LE Software

After the Apple System software settings are configured, you're ready to install Pro Tools LE.

### Installing Pro Tools on Mac OS X

#### To install Pro Tools LE on Mac OS X:

- 1 Make sure you are logged into an administrator account where you want to install Pro Tools LE. For details on Administrator privileges in Mac OS X, refer to your Apple OS X documentation.
- 2 Insert the Pro Tools LE 6.x Installer CD-ROM in your CD-ROM drive. Double-click "Install Pro Tools LE."
- 3 Enter your Administrator password and click OK to authenticate the installation.
- 4 Select your Startup hard drive as the install location and click Install.
- 5 When installation is complete, click Restart.  
– or –

Click Continue to install any additional software or documentation, and restart your computer when you are finished.

 *If you plan to use any MIDI devices with Pro Tools, configure your MIDI setup with the Apple Audio MIDI Setup (AMS) utility. See Appendix B, "Configuring AMS (Mac OS X Only)" for details.*

### Removing Pro Tools LE on Mac OS X

If you need to remove Pro Tools LE from your computer, you can use the Installer CD-ROM.

#### To remove Pro Tools LE from your computer:

- 1 Make sure you are logged in as an Administrator for the account where Pro Tools LE is installed. For details on Administrator privileges in Mac OS X, refer to your Mac OS X documentation.
- 2 Insert the Pro Tools LE Installer CD-ROM in your CD-ROM drive. Double-click "Install Pro Tools LE."
- 3 Enter your Administrator password and click OK to authenticate the installation.
- 4 In the Installer window, choose Uninstall from the pop-up menu, and click Uninstall.
- 5 Click Quit to close the Installer window.

### Installing Pro Tools on Mac OS 9

#### To install Pro Tools LE on Mac OS 9:

- 1 Insert the Pro Tools LE 5.1.1 Installer CD in your CD-ROM drive. Double-click "Install Pro Tools LE."
- 2 In the Installer window, select "Pro Tools LE" and make sure the Install Location is on your startup drive.
- 3 If you want to use Digi 001 with Apple Sound Manager-compatible applications, select the Digidesign Control Panel option. See Appendix E, "Digidesign Control Panel (Mac OS 9 Only)."
- 4 Click Install.
- 5 When installation is complete, do one of the following:
  - Click Quit and install OMS (see "Installing OMS" on page 21) if it is not already installed on your system.
  - Click Restart.

## Removing Pro Tools LE on Mac OS 9

If you need to remove Pro Tools LE from your computer, you can use the Installer CD-ROM.

### To remove Pro Tools LE from your computer:

- 1 Insert the Pro Tools LE 5.1.1 Installer CD-ROM in your CD-ROM drive. Double-click “Install Pro Tools LE 5.1.1.”
- 2 In the Installer window, choose Uninstall from the pop-up menu, and click Uninstall.
- 3 Click Quit to close the Installer window.

---

## Installing OMS

### (Mac OS 9 Only)

To use Pro Tools on Mac OS 9, you must first install and configure the Open Music System (OMS), which is included on the Pro Tools Installer CD-ROM.

 *Even if you don't intend to use MIDI in your Pro Tools sessions, you still need to install OMS. The Pro Tools application will not launch without it.*

### To install OMS:

- 1 Insert the Pro Tools LE 5.1.1 Installer CD in your CD-ROM drive.
- 2 Open the OMS Installer folder and double-click the OMS installer.
- 3 At the Install window, select the Easy Install option, and set the Install Location to your Startup hard drive. Click Install.
- 4 Follow the on-screen installation instructions.

- 5 When installation is complete, click Restart.

 *For more information on configuring OMS, see Appendix D, “Configuring OMS (Mac OS 9 Only).”*

---

## Installing the Demo Session

### (Optional)

The Pro Tools LE Installer CD-ROM includes a demo session that you can use to verify that your system is working.

### To install the demo session:

- 1 Insert the Pro Tools LE Installer CD in your CD-ROM drive. Locate and double-click the demo session installer icon.
- 2 Select your audio drive as the install location and click Install.
- 3 When installation is complete, click Quit.

---

## Launching Pro Tools LE

When launching Pro Tools LE the first time, you are prompted to enter an authorization code to validate your software.

With new Digi 001 systems, the authorization code is located on the inside cover of the *Getting Started with Digi 001 Guide*. With software upgrades, the authorization code is located on the inside cover of the *Upgrading Guide*.

### To authorize Pro Tools LE software:

- 1 Double-click the Pro Tools LE application, located in the Pro Tools folder, inside the DigiDesign folder.

2 With Mac OS 9, if OMS was not previously configured, you will be prompted to configure a New Studio Setup. For specific steps, see Appendix D, “Configuring OMS (Mac OS 9 Only).”

3 Enter the authorization code in the dialog when prompted (making sure to type it exactly as printed, and observing any spaces and capitalization) then click Validate.

---

## Configuring Pro Tools LE System Settings

You can adjust the performance of your system by changing system settings that affect its capacity for processing, playback, and recording.

In most cases, the default settings for your system provide optimum performance, but you may want to adjust them to accommodate large or processing-intensive Pro Tools sessions.

### Hardware Buffer Size

The Hardware Buffer Size (H/W Buffer Size) controls the size of the hardware cache used to handle host processing tasks such as Real-Time AudioSuite (RTAS) plug-ins.

- ◆ Lower Hardware Buffer Size settings reduce monitoring latency, and are useful when you are recording live input.
- ◆ Higher Hardware Buffer Size settings allow for more audio processing and effects, and are useful when you are mixing and using more RTAS plug-ins.

**⚠** *In addition to causing slower screen response and monitoring latency, higher Hardware Buffer Size settings can affect the accuracy of plug-in automation, mute data, and timing for MIDI tracks.*

### To change the Hardware Buffer Size:

- 1 Choose **Setup > Playback Engine**.

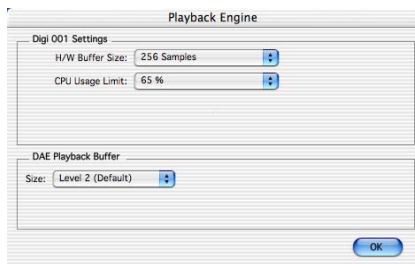

Playback Engine dialog for Digi 001 (Pro Tools 6.x)

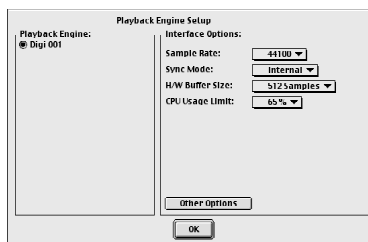

Playback Engine dialog for Digi 001 (Pro Tools 5.1.1)

- 2 From the H/W Buffer Size pop-up menu, select the audio buffer size, in samples.

- 3 Click **OK**.

### CPU Usage Limit

The CPU Usage Limit controls the percentage of CPU resources allocated to Pro Tools host processing tasks.

- ◆ Lower CPU Usage Limit settings limit the effect of Pro Tools processing on other CPU-intensive tasks, such as screen redraws, and are useful when you are experiencing slow system response, or when running other applications at the same time as Pro Tools.

◆ Higher CPU Usage Limit settings allocate more processing power to Pro Tools, and are useful for playing back large sessions or using more real-time plug-ins.

⚠ *Increasing the CPU Usage Limit may slow down screen responses on slower computers.*

◆ With Pro Tools 5.1.1, the maximum CPU Usage Limit is 85 percent.

◆ With Pro Tools 6.x, the maximum CPU Usage Limit is 85 percent for single-processor computers, and 99 percent for multi-processor computers. (The 99 percent setting dedicates one entire processor to Pro Tools.)

#### To change the CPU Usage Limit:

1 Choose Setups > Playback Engine.

2 From the CPU Usage Limit pop-up menu, select the percentage of CPU processing you want to allocate to Pro Tools.

3 Click OK.

◆ Lower CPU Usage Limit settings limit the effect of Pro Tools processing on other CPU-intensive tasks, such as screen redraws, and are useful when you are experiencing slow system response, or when running other applications at the same time as Pro Tools.

◆ Higher CPU Usage Limit settings allocate more processing power to Pro Tools, and are useful for playing back large sessions or using more real-time plug-ins.

⚠ *Increasing the CPU Usage Limit may slow down screen responses on slower computers.*

## DAE Playback Buffer Size

The DAE Playback Buffer Size determines the amount of memory DAE uses to manage disk buffers, which affects system performance.

◆ Lower DAE Playback Buffer Size settings can improve playback and recording initiation speed. However, a lower setting can make it difficult for slower hard drives to play or record tracks reliably.

◆ Higher DAE Playback Buffer Size settings can allow for a higher density of edits in a session. However, a higher setting can cause a time lag to occur before playback or recording begins. It can also cause a time lag to occur when you are editing during playback.

#### To change the DAE Playback Buffer Size in Pro Tools 6.x:

1 Choose Setups > Playback Engine.

2 From the DAE Playback Buffer pop-up menu, select a buffer size.

3 Click OK.

#### To change the DAE Playback Buffer Size in Pro Tools 5.1.1:

1 Launch DAE. If Pro Tools is already running, switch to the DAE application by choosing it from the Application menu.

2 Choose File > Set Playback Buffer Size.

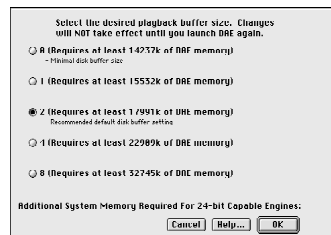

DAE Playback Buffer Size dialog (Pro Tools 5.1.1)

3 Select a playback buffer size.

4 Click OK.

5 Quit Pro Tools if it is running. The new buffer setting will take effect when you launch Pro Tools again.

## Pro Tools Hardware Settings

Using the Hardware Setup dialog, you can select the default sample rate, clock source, digital input format, and input gain settings for your Digi 001 system.

### Default Sample Rate

The Sample Rate setting appears as the default sample rate when you create a new session. (This setting is available in the Hardware Setup dialog only when no session is open.)

 You can change the sample rate when creating a new Pro Tools session. (See “Starting a Session” on page 45.)

#### To change the default Sample Rate:

1 Make sure that no Pro Tools session is open.

2 Choose **Setup > Hardware Setup** (Pro Tools 6.x) or **Setup > Hardware** (Pro Tools 5.1.1).

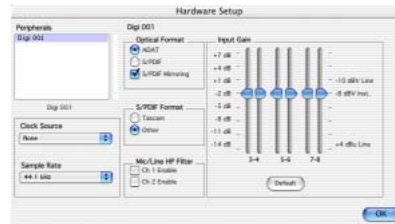

Hardware Setup dialog for Digi 001 (Pro Tools 6.x)

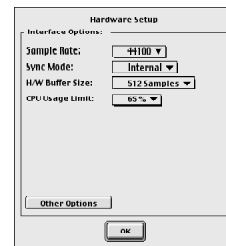

Hardware Setup dialog for Digi 001 (Pro Tools 5.1.1)

3 Choose the sample rate from the Sample Rate pop-up menu.

4 Click OK.

### Clock Source

Using the Hardware Setup dialog, you can select the Clock Source for the system. (Clock Source is called “Sync Mode” in Pro Tools 5.1.1.)

#### Internal

If you are recording an analog signal directly into Digi 001, you will usually use the Pro Tools Internal clock source. The Clock Source automatically changes to Internal when you change the Ch. 1–2 Input to Analog.

## SPDIF/RCA

If you are transferring material into Pro Tools from an external digital device, you will usually synchronize Pro Tools to that digital device. The Clock Source automatically changes to SP-DIF/RCA when you change the Ch. 1-2 Input to SPDIF/RCA.

### To select the Clock Source:

- 1 Choose Setups > Hardware Setup (Pro Tools 6.x) or Setups > Hardware (Pro Tools 5.1.1).
- 2 Select a clock source from the Clock Source pop-up menu (Pro Tools 6.x) or the Sync Mode pop-up menu (Pro Tools 5.1.1).
- 3 Click OK.

## Digital I/O Format

Pro Tools LE provides controls for setting the digital I/O format and S/PDIF compatibility of Digi 001.

### To change the digital I/O format settings:

- 1 Choose Setups > Hardware Setup (Pro Tools 6.x) or Setups > Hardware (Pro Tools 5.1.1).

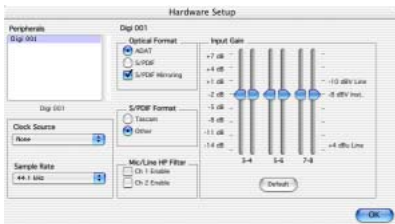

Hardware Setup dialog for Digi 001 (Pro Tools 6.x)

### 2 In Pro Tools 5.1.1, click Other Options.

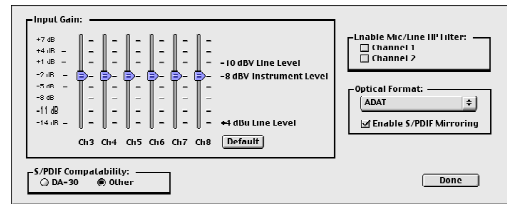

Other Options dialog for Digi 001 (Pro Tools 5.1.1)

### 3 Set the controls for the following options:

**Optical Format** Select ADAT or S/PDIF, depending on whether you are using the Optical inputs and outputs for ADAT or S/PDIF format.

**S/PDIF Mirroring** When this option is enabled, the S/PDIF (RCA) outputs (outputs 17 and 18) automatically mirror the audio that is sent to analog outputs 1 and 2.

**S/PDIF Format (Pro Tools 6.x) or S/PDIF Compatibility (Pro Tools 5.1.1)** Set the S/PDIF I/O format to DA-30 if you are using a Tascam DA-30 DAT recorder. Otherwise, select Other.

4 In Pro Tools 5.1.1, click Done to close the Other Options window.

5 Click OK to close the Hardware Setup dialog.

## Input Gain and High Pass Filter

You can adjust the input gain on input channels 3–8, and insert a high-pass filter on input channels 1–2.

### To change the input gain and filter settings:

- 1 Choose Setups > Hardware Setup (Pro Tools 6.x) or Setups > Hardware (Pro Tools 5.1.1).
- 2 In Pro Tools 5.1.1, click Other Options.
- 3 Set the controls for the following options:

**Input Gain** You can adjust the gain on analog channels 3–8 by dragging the Input Gain sliders.

**Mic/Line HP Filter** You can enable a high-pass filter (set at 60 Hz) on Channels 1 and 2 for filtering out low-end rumble from a noisy recording environment, microphone handling, or AC noise.

- 4 In Pro Tools 5.1.1, click Done to close the Other Options window.
- 5 Click OK to close the Hardware Setup dialog.

## Recording a Digital Source

If you are recording from an optical or S/PDIF device, you will need to configure Pro Tools LE to synchronize to the external device.

### To configure Pro Tools LE for a digital source:

- 1 Connect an ADAT or S/PDIF format optical device to the Optical In on the Digi 001 PCI Card, or connect an RCA S/PDIF device to the RCA connectors on the back of the Digi 001 I/O Box.

**⚠** You can only use one pair of S/PDIF inputs (either RCA or optical) at a time.

- 2 Choose Setups > Hardware Setup (Pro Tools 6.x) or Setups > Hardware (Pro Tools 5.1.1).

- 3 Select Optical or S/PDIF (RCA) from the Clock Source menu (Pro Tools 6.x) or the Sync Mode pop-up menu (Pro Tools 5.1.1), depending on where you connected your digital device. (See Figure 1.)

**⚠** Your digital input device must be connected and powered on. If your input device is not powered on, leave the Clock Source set to Internal.

- 4 In Pro Tools 5.1.1, click Other Options.
- 5 If you are using the S/PDIF (RCA) input, set the S/PDIF Format to DA-30 or Other depending on whether or not you are using a Tascam DA-30.

– or –

If you are using the optical input on the Digi 001 PCI Card, select the correct Optical Input Format (ADAT or S/PDIF).

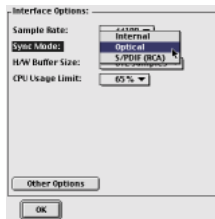
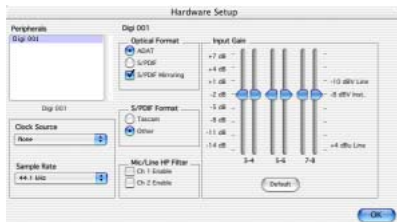

Figure 1. Setting the Clock Source in Pro Tools 6.x (left) and the Sync Mode in Pro Tools 5.1.1 (right)



## Configuring I/O Setup

Using the I/O Setup dialog, you can label Pro Tools LE input, output, insert, and bus *signal paths*. The I/O Setup dialog provides a graphical representation of the inputs, outputs, and signal routing of the Digi 001.

Pro Tools LE has default I/O Setup settings that will get you started. Use the I/O Setup dialog only if you want to rename the default I/O paths.

### To configure I/O routing in I/O Setup:

- 1 Choose Setups > I/O Setup.

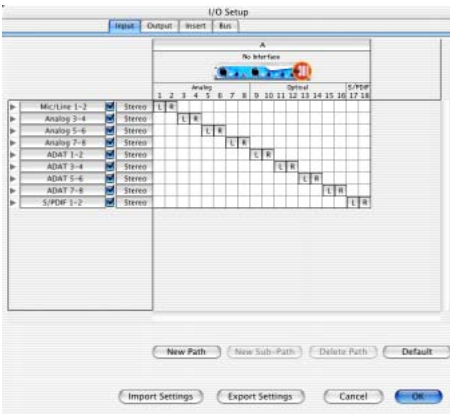

*I/O Setup dialog for Digi 001, Input page*

- 2 Click the Input, Output, Insert, or Bus tab to display the corresponding connections.
- 3 To change the name of a path or subpath, double-click directly on the Path Name, type a new name for the path, and press Return.
- 4 Click OK.

 Refer to the *Pro Tools Reference Guide* for more information on renaming I/O paths.



## chapter 4

# Digi 001 Overview

### Digi 001 I/O Box Inputs and Outputs

All Digi 001 inputs and outputs are factory calibrated for 14 dB of headroom below 0 dB, or full code. This means at the nominal reference input level (+4 dBu or -10 dBV) you can have up to 14 dB of headroom before input or output clipping occurs.

### Connectors on the Digi 001 I/O Box Front Panel

#### Mic/Line Inputs 1 and 2

These balanced/unbalanced inputs are designed for microphones or line-level inputs (with the -26 dB pad). They accept XLR or 1/4-inch analog audio input connections.

#### -26 dB Pads 1 and 2

These switches accommodate line-level signals on Mic/Line Input 1 and 2 by reducing input sensitivity by -26 dB.

#### Input Gain 1 and 2

These controls adjust the input gain of Mic/Line inputs 1 and 2.

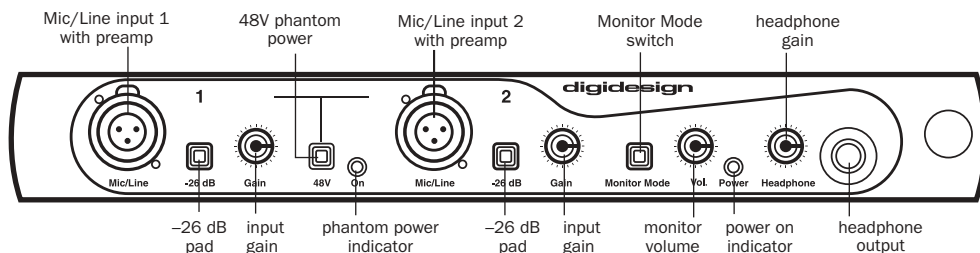

Figure 2. Digi 001 I/O Box, front panel

## Phantom Power

This switch applies 48V phantom power to Mic/Line inputs 1 and 2. These inputs provide 48V phantom power for microphones that require it to operate.

*Dynamic* microphones (like a Shure SM57) do not require phantom power to operate, but are not harmed by it. Most *condenser* microphones (like an AKG C414) *do* require phantom power to operate. If you are not sure about the phantom power requirements for your microphone, contact the manufacturer, or read your microphone's documentation.

**⚠** *Although phantom power can be used safely with most microphones, ribbon microphones can be destroyed by it. Always turn off phantom power, and wait for the red phantom power indicator light to go completely off before connecting or disconnecting a ribbon microphone.*

## Phantom Power Indicator

When lit (red), this LED indicates that phantom power is on.

## Monitor Mode

When this switch is pushed in, the Digi 001 I/O switches to Monitor Mode, which monitors analog inputs 3–4 on the Digi 001 I/O Box even when the power for your computer is off. Use Monitor mode to monitor an audio device such as a CD player or synth without turning on the computer.

## Monitor Volume

This control adjusts the output level of the Left and Right Monitor Outputs. This control also adjusts the level of these outputs when the I/O is in Monitor Mode. The monitor outputs mirror the audio routed to outputs 1–2 in software and on the I/O.

## Power On Indicator

When lit (green), this LED indicates that the Digi 001 I/O Box is on. Your computer must be powered on to power the Digi 001.

## Headphone Gain

This control adjusts the output level of the headphone jack.

## Headphone Output

Use the Headphone Output to connect stereo headphones. This jack accepts a 1/4-inch stereo plug. This outputs any audio that is routed to analog outputs 1–2 in Pro Tools LE. The Headphone Output is disabled in unpowered Monitor Mode (see “Monitor Mode” on page 30 for more information).

## Connectors on the Digi 001 I/O Box Back Panel

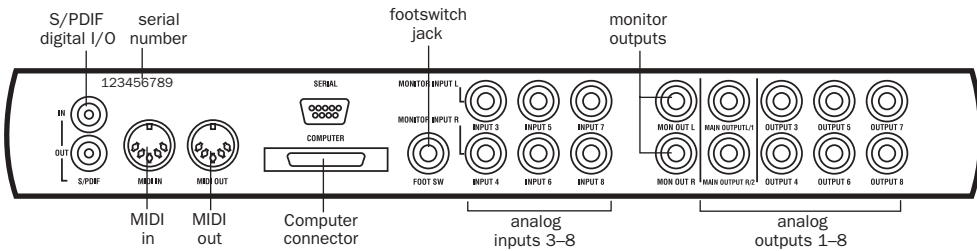

Figure 3. Digi 001 I/O Box, back panel

### S/PDIF Digital I/O

The Sony Phillips Digital Interface Format (S/PDIF) is used in many professional and consumer CD players and DAT recorders. The S/PDIF in/out jacks are unbalanced 2-conductor phono (RCA) jacks that utilize a full 24-bit, 2-channel digital data stream. To avoid RF interference, use 75-ohm coaxial cable for S/PDIF transfers and keep the cable length to a maximum of 10 meters.

### MIDI I/O

The MIDI connectors on the Digi 001 I/O Box let Digi 001 to act as a MIDI interface.

- ◆ On Mac OS 9, a Digi 001 driver for OMS is installed with Pro Tools LE.
- ◆ On Mac OS X, a Digi 001 driver for AMS is installed with Pro Tools LE.
- ◆ On Windows, a Windows Multimedia MIDI driver for the Digi 001 is installed with Pro Tools LE.

One MIDI input and one MIDI output let you send and receive MIDI on 16 channels. These connectors accept standard 5-pin MIDI cables. Digi 001 MIDI I/O can be used in addition to any other MIDI interfaces you are using.

### Computer Connector

This connector is used to connect the I/O to the Digi 001 PCI card. The cable for this is supplied with your system.

### Footswitch Jack

Use this connector to plug in a footswitch that can be used for control of QuickPunch audio punch-in and punch-out, and for MIDI punch-in and punch-out recording features (see “Editing” on page 63). Both continuous on/continuous off and instantaneous on/off pedals with a 1/4-inch TRS connector are supported.

### Monitor Inputs (Analog Inputs 3–4)

These connectors are used to connect analog audio sources 3–4, or to connect a stereo source such as a CD player, synth, or cassette deck to monitor when using the Digi 001 I/O Box in Monitor Mode. In Monitor Mode, input 3 is routed to the Left output and input 4 is routed to the Right output. These connectors are balanced, 1/4-inch jacks.

## Analog Inputs 3–8

These inputs are used to connect analog audio sources that are routed to Analog Inputs 3–8. These are balanced, 1/4-inch jacks for analog audio input connections. These analog inputs feature 24-bit analog-to-digital converters.

## Monitor Outputs

These outputs can be connected to powered speakers, a stereo power amp, or another stereo destination to monitor your mix. The monitor outputs play the audio that is routed to analog outputs 1 and 2. Analog output 1 material is routed to the left monitor output, and analog output 2 material is routed to the right monitor output. These analog outputs feature 24-bit digital-to-analog converters. You can control the output level of the monitor outputs with the Monitor Volume control. These connectors are balanced, 1/4-inch jacks.

## Main Analog Outputs 1–2

These main outputs play the audio that is routed to analog outputs 1–2. These outputs can provide left and right outputs to a tape deck for mixdowns, or to another stereo destination. These analog outputs feature 24-bit digital-to-analog converters. These outputs are balanced, +4 dBu line level. The connectors are 1/4-inch jacks.

## Analog Outputs 3–8

These outputs play the audio that is routed to analog outputs 3–8. These analog outputs feature 24-bit digital-to-analog converters. These outputs are unbalanced, –10 dBu line level. The connectors are 1/4-inch jacks.

---

## Connectors on the Digi 001 PCI Card

The Digi 001 PCI Card installs in an available PCI slot in your computer. The PCI Card includes optical digital I/O for 8 channels of ADAT I/O or 2 channels of S/PDIF I/O. The card also includes a connector for the Digi 001 I/O Box.

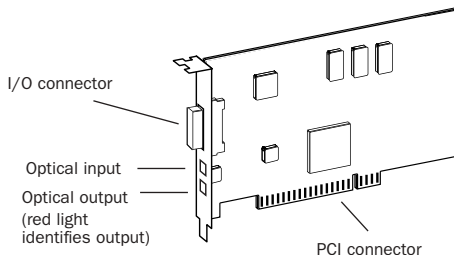

*Digi 001 PCI card*

### Optical Input

The optical input connects to an optical digital audio source. This can be either an 8-channel ADAT format audio source or a 2-channel S/PDIF audio source. The digital format that this input accepts is switchable in Pro Tools LE. This connection provides up to 24-bit digital audio for either format. This format uses a standard optical (TOS-link) cable. One optical cable is included with Digi 001.

### Optical Output

The optical output sends optical digital audio to a destination such as a digital mixer or a digital recorder. This can be either an 8-channel ADAT format destination or a 2-channel S/PDIF audio destination. The digital output format is switchable in Pro Tools LE. This connection provides up to 24-bit digital audio for either format. This format uses a standard optical “lightpipe” cable. One optical cable is included with Digi 001.

## chapter 5

# Connecting Your Studio

This chapter explains how to connect your Digi 001 to a mixer, amplification system, digital recorders, and other studio devices, and how to connect audio sources for recording.

You can use Digi 001 with a variety of audio setups, including:

- a mixer, power amplifier, and speakers
- a mixer and a pair of amplified, self-powered speakers
- a stereo receiver and speakers
- a pair of amplified, self-powered speakers
- headphones

## Studio Setup Diagrams

Your setup will differ depending on which of these systems you use. The illustrations that follow show two typical home studio setups.

Figure 4 on page 34 shows a studio configuration using a mixer, and Figure 5 on page 35 shows a studio configuration without a mixer.

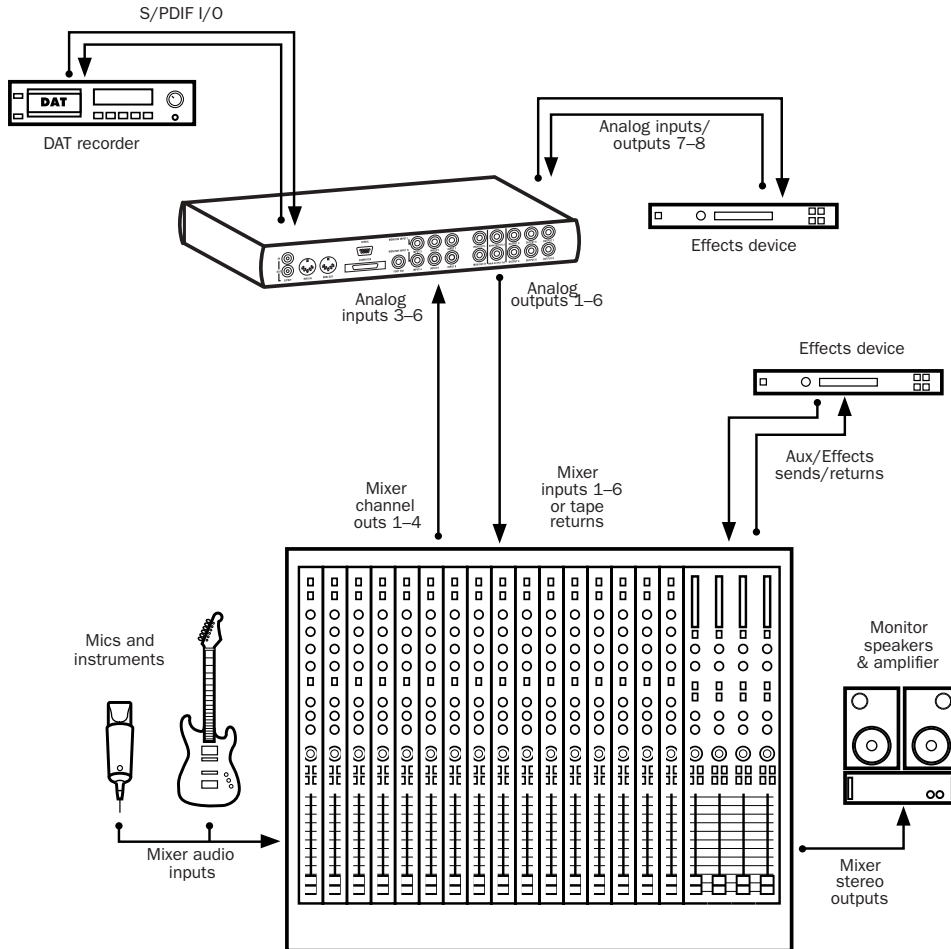

Figure 4. Digi 001 studio configuration with a mixer



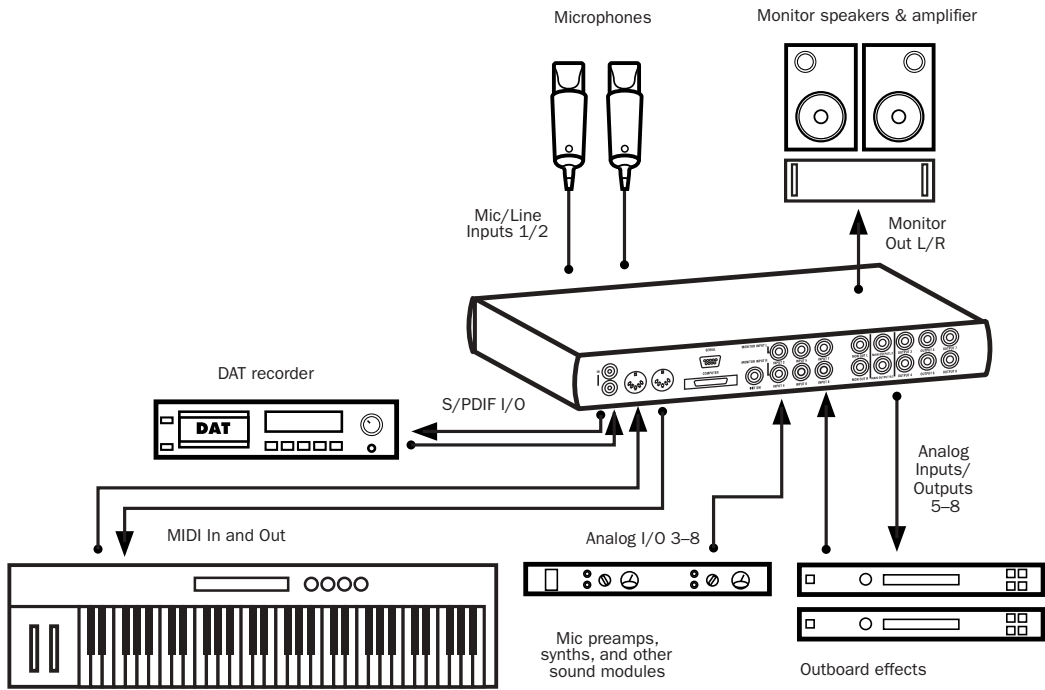

Figure 5. Digi 001 studio configuration without a mixer

## Monitoring Audio

Monitoring volume for speakers connected to the Monitor Outputs is controlled with the Monitor Volume knob (see “Monitor Volume” on page 30 for more information). Headphone volume is controlled with the Headphone Gain knob (see “Headphone Gain” on page 30 for more information).

**⚠** You cannot monitor Pro Tools audio through speakers connected to your computer. To monitor audio, connect headphones, powered speakers, or an external amplifier to your Digi 001.

### To connect headphones:

1 Connect headphones to the Headphone jack on the Digi 001 I/O Box. The Headphone input accepts a stereo 1/4-inch plug. If your headphones have a smaller “mini-plug,” purchase an adapter from your local dealer. For best results, use high-quality, closed-ear headphones.

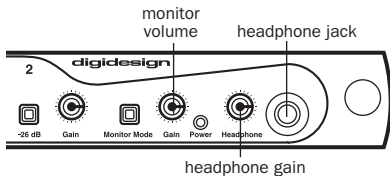

### Gain controls and headphone jack

2 Adjust headphone volume with the Headphone Gain knob.

**⚠** The Digi 001 headphone output can produce very loud output levels. Prolonged exposure can cause hearing damage. Adjust headphone volume carefully.

### To connect a home stereo:

1 Connect 1/4-inch cables to the Monitor Outputs on the back of the Digi 001 I/O Box.

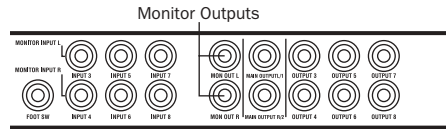

### Monitor Outputs

2 Connect the outputs to an available pair of left and right inputs on your stereo.

**💡** Home stereo systems often use RCA connectors. You can use an adaptor or a special cable to convert from the 1/4-inch connectors used by Digi 001 to the RCA connectors on your home stereo.

### To connect monitor speakers with a power amp or self-powered monitor speakers:

1 Connect 1/4-inch cables to the Monitor Outputs on the back of the Digi 001 I/O Box.

2 Connect the outputs from Digi 001 to the left and right power amp inputs, or to the left and right self-powered speakers.

---

## Connecting Audio Sources to Digi 001

Audio sources of two types can be used with Digi 001: analog or digital.

### Analog Audio

Analog audio signals are output by microphones, synths, mixers, and instruments with magnetic pickups. Of these sources, microphones and magnetic pickup instruments output the quietest signals, and generally require the most amplification. Digi 001 includes preamps for these sources on Mic/Line inputs 1 and 2, and 48V phantom power for both channels. Mic/Line inputs 1 and 2 accept XLR or 1/4-inch connectors.

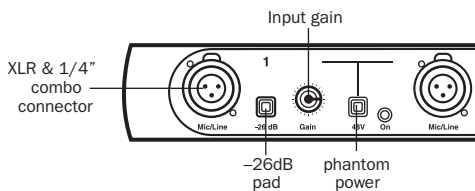

#### Analog preamp input

Keyboards, preamps, and mixers output “line-level” audio, which varies with each device between the -10 and +4 standards. Use Digi 001’s line-level inputs 3–8 (on the back of the Digi 001 I/O Box) for these devices. Digi 001 includes software controllable gain to accommodate the different line levels that these devices can generate (see “Input Gain and High Pass Filter” on page 15 for Windows or “Input Gain and High Pass Filter” on page 26 for Macintosh). Inputs 3–8 accept 1/4-inch connectors. You can also connect line-level signals to Mic/Line inputs 1 and 2 on the front by pressing the -26 dB pad switch.

#### To connect an analog audio source:

- Plug a microphone directly into Mic/Line Input 1 or 2 on the front of the Digi 001 I/O Box (see Figure 6 on page 38). These inputs accept XLR connectors or 1/4-inch TRS connectors. If your microphone requires phantom power, press the Phantom Power switch (labeled 48V).

**⚠** *Although phantom power can be used safely with most microphones, ribbon microphones can be destroyed by it. Always turn off phantom power and wait for the red light to go completely off before connecting or disconnecting a ribbon microphone.*

- Plug line-level sources (synths, outputs from your mixer, or microphones or guitars that have been amplified by an outboard preamp) into the analog inputs on the back of the Digi 001 I/O Box (see Figure 7 on page 38).

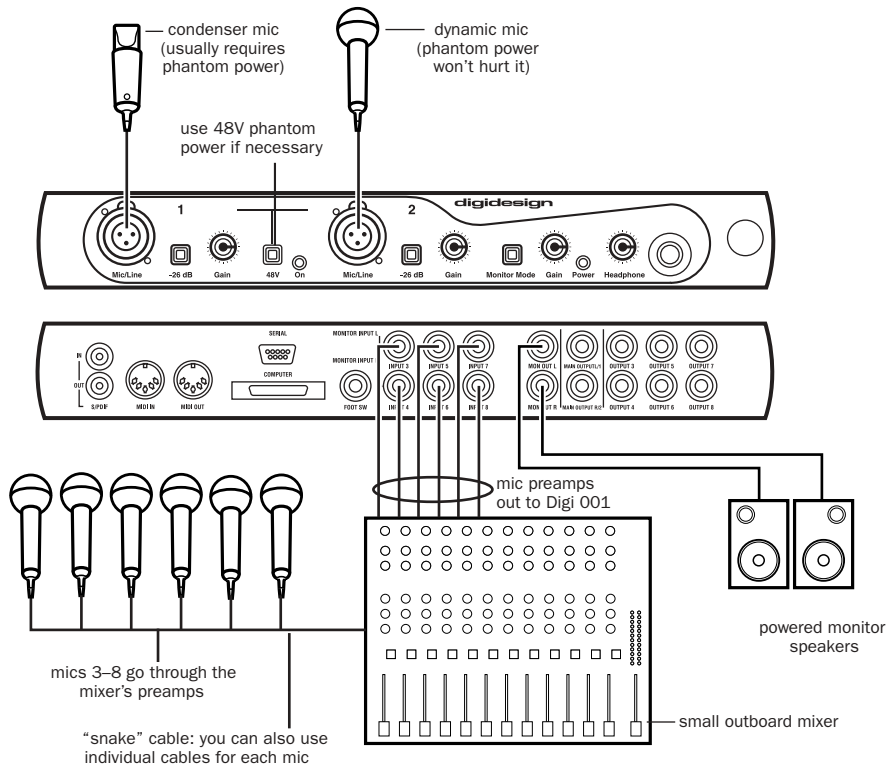

Figure 6. Connecting several microphones to a Digi 001

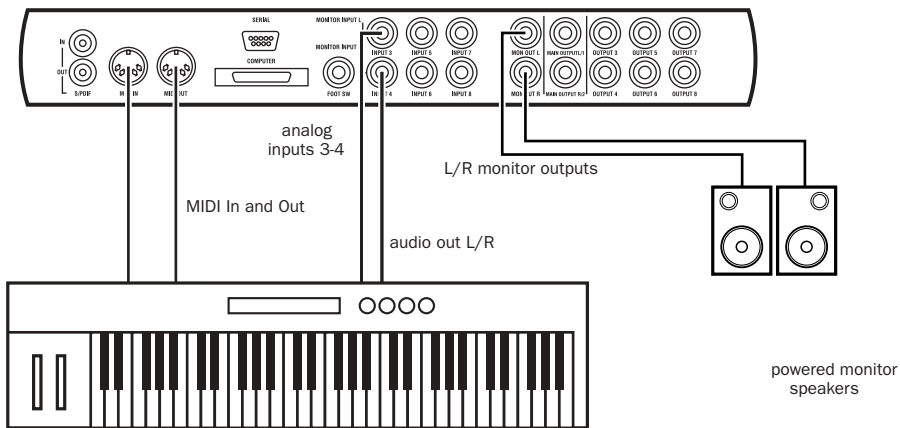

Figure 7. Connecting a synth to a Digi 001

## Digital Audio

Digi 001 provides digital inputs and outputs, including:

- Optical input and output for eight channels of ADAT input or two channels of S/PDIF input
- Two channels of S/PDIF digital I/O (RCA)

### ADAT Format

The ADAT format was developed by Alesis for use in their ADAT multitrack recorders. Each ADAT optical connection provides 8 channels of digital audio with 24-bit capability. You can connect an ADAT or other ADAT optical format device directly to the optical I/O on the Digi 001 PCI Card (see “Connecting an ADAT to Digi 001” on page 43). The optical I/O connectors accept optical cables.

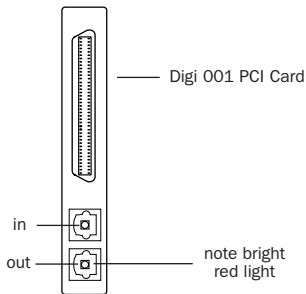

Optical I/O on the Digi 001 PCI Card

### S/PDIF

S/PDIF (Sony/Phillips Digital Interchange Format) I/O is available on many DAT decks, compact disc players, and other digital devices. Each S/PDIF connection provides 2 channels of digital audio with 24-bit capability. You can connect a S/PDIF digital input to either the Optical connectors on the Digi 001 PCI card, or to the S/PDIF RCA connectors on the back of the

Digi 001 I/O Box (see “Connecting a Digital Deck (DAT)” on page 42). The optical connectors accept optical cables; the RCA connectors accept RCA cables.

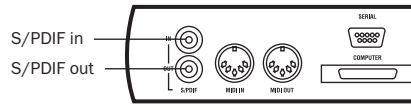

S/PDIF Input and Output

**⚠** Only one S/PDIF input pair can be used at a time. For example, if you use the optical input for S/PDIF data, you cannot use the RCA inputs.

### S/PDIF Mirroring

Pro Tools LE uses S/PDIF mirroring to automatically “mirror” the audio that is sent to outputs 1 and 2 on the S/PDIF RCA outputs. This is useful if you are monitoring a mix using your audio outputs, and also recording the same source to an external S/PDIF device.

Disable S/PDIF mirroring if you want to use the S/PDIF outs to send a separate signal to an external digital effects unit, or if you want to send only certain outputs to the digital device. If you disable S/PDIF mirroring you can select the S/PDIF outputs separately, and route tracks or sends to them.

For details on setting S/PDIF mirroring, see “Digital I/O Format” on page 14 (Windows) or “Digital I/O Format” on page 25 (Macintosh).

---

## Using External Effects Devices

The Digi 001 can make dedicated connections to external analog or digital devices. You can send and return signals to analog devices using the analog inputs and outputs on the Digi 001 I/O Box. You can also send and return a digital signal to an external device that supports digital I/O (such as a reverb unit), and monitor with the analog outputs or (if unused) the other digital output.

If you want to use the digital inputs and outputs on your Pro Tools LE system as effects sends and returns to a digital effects device, Pro Tools LE should be the clock master in most cases. Set your digital effects device to accept an external digital clock so that it synchronizes to Pro Tools LE.

### To connect an external analog device to your system:

- 1 Connect an unused output (or outputs if stereo) on the Digi 001 I/O Box to an input (or inputs if stereo) of the external signal processor.
- 2 Connect the output (or outputs if stereo) of the external signal processor to an unused input (or pair of inputs if stereo) on the Digi 001 I/O Box.

### To set up a send to an external digital device (digital sends/returns only):

- 1 Choose Setups > Hardware Setup.
- 2 On Mac OS 9, click Other Options.
- 3 Do one of the following:
  - If the external device is connected to the S/PDIF RCA jacks, deselect S/PDIF Mirroring. (When S/PDIF Mirroring is on, digital output at the S/PDIF RCA jacks exactly mirrors the output of analog Channels 1–2.) If you disable S/PDIF Mirroring, you must reconfigure your I/O Setup to reflect this change. Refer to the *Pro Tools Reference Guide* for details on configuring the I/O Setup dialog.
  - If the external device is connected to the Optical ports, choose a format (most likely S/PDIF for an effects device) from the Optical Format pop-up menu.
- 4 On Mac OS 9, click Done to close the Other Options dialog.
- 5 Choose Internal from the Sync Mode pop-up menu (Mac OS 9) or the Clock Source pop-up menu (Mac OS X and Windows).
- 6 Click OK to close the Hardware Setup dialog.

 You can use the I/O Setup dialog (Setups > I/O Setup) to label the inputs and outputs you are using in Pro Tools LE and identify them as inserts or sends when working in a session. Refer to the *Pro Tools Reference Guide* for details.

# Using Monitor Mode

## (Stand Alone)

The Monitor Mode feature monitors analog inputs 3–4 on the Digi 001 I/O Box even when the power for your computer is off, or your Digi 001 I/O Box is disconnected from the computer. You can use this to monitor a CD player, synth, or tape machine without an external mixer, and without your computer on.

### To use Monitor Mode:

- 1 Connect analog audio outputs of your device to analog Inputs 3 and 4 on the back of the Digi 001 I/O Box.
- 2 Connect speakers for monitoring audio to the Monitor Outputs on the back of the Digi 001 I/O Box (see “Monitoring Audio” on page 36 for connection information).
- 3 Press the Monitor Mode switch in.
- 4 Adjust the monitoring volume using the Monitor Gain knob.

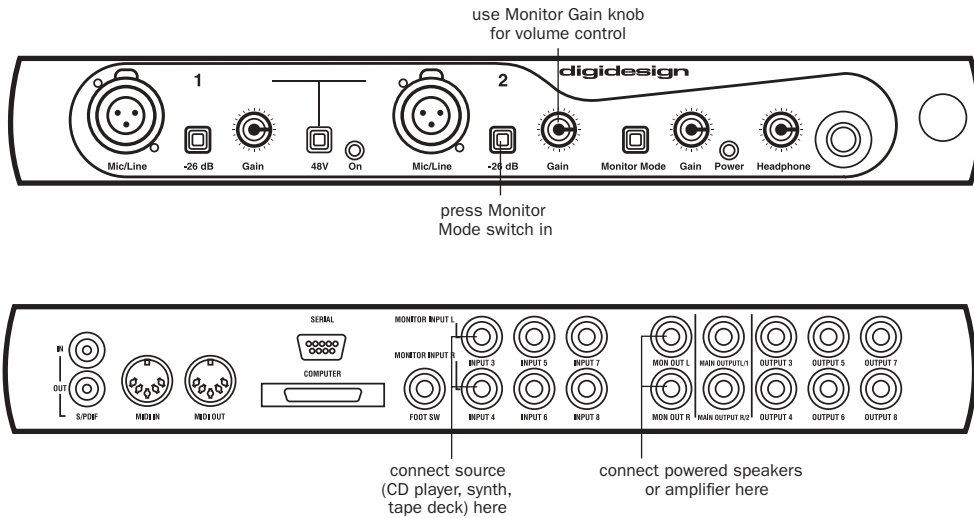

Figure 8. Using Monitor Mode

---

## Connecting a Recorder for Mixdowns

After you record and mix your sessions using your Digi 001, you may want to mix them down to a DAT or other stereo 2-track recording device.

### Connecting an Analog Deck

Connect your analog deck's inputs to the Main outputs on the back of the Digi 001 I/O Box. L/1 connects to the left input of your recorder, and R/2 connects to the right input. These outputs are 1/4-inch jacks. You may need adapter cables if your mixdown deck has RCA inputs.

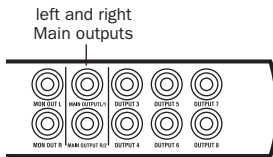

*Main Outputs*

### Connecting a Digital Deck (DAT)

If you have a DAT or other digital device that can send or receive S/PDIF digital audio data, connect it to the S/PDIF In and S/PDIF Out RCA jacks on the back of the Digi 001 I/O Box.

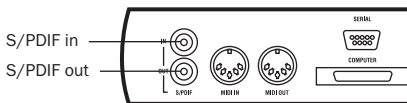

*S/PDIF Input and Output*

### Connecting Tascam DA-30 DAT Recorders

If connecting to a Tascam DA-30 DAT recorder, set the S/PDIF I/O format to Tascam (Windows) or DA-30 (Macintosh) in Pro Tools LE.



## Connecting an ADAT to Digi 001

To connect an ADAT to Digi 001:

- 1 Connect the ADAT optical output to the Optical In port on the Digi 001 PCI Card (see Figure 9 on page 43).
- 2 Connect the ADAT optical input to the Optical Out port on the Digi 001 PCI Card (see Figure 10 on page 43). When the Digi 001 is on, its Optical Out port emits a red light.

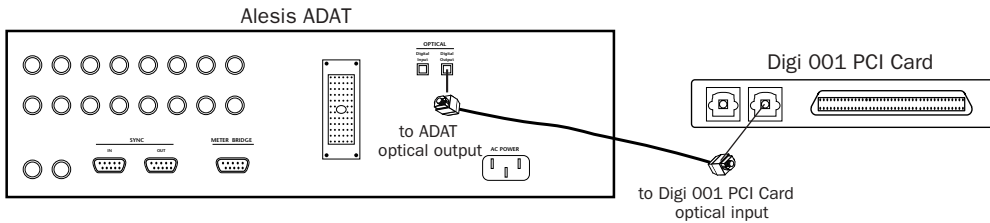

Figure 9. Connecting ADAT optical output to the Digi 001 PCI Card optical input

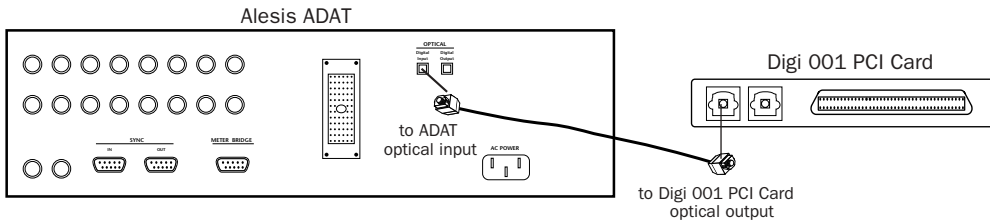

Figure 10. Connecting ADAT optical input to the Digi 001 PCI Card optical output

---

## Connecting a Footswitch

You can connect a footswitch to the Digi 001 that can be used for control of QuickPunch audio punch-in and punch-out, and for MIDI punch-in and punch-out recording features (see “Editing” on page 63). Both continuous on/continuous off and instantaneous on/off pedals with a 1/4-inch TRS connector are supported.

**▲** *Pro Tools LE only detects the footswitch if you connect it to the Digi 001 I/O Box before you launch Pro Tools LE.*

### To connect a footswitch to Digi 001:

- Plug a footswitch into the Footswitch connector on the back of the Digi 001 I/O Box.

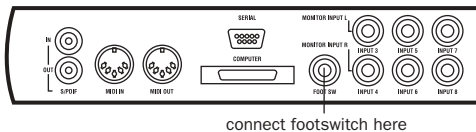

*Digi 001 footswitch jack*

---

## MIDI Connections

Using the Digi 001’s built-in MIDI ports, or an external MIDI Interface, with a MIDI keyboard controller or other MIDI devices, you can take full advantage of the MIDI features of Pro Tools LE. These include recording and editing MIDI tracks, synchronizing to MIDI Time Code or MIDI Beat Clock (this requires an appropriate MIDI interface) and using a MIDI control surface.

- ◆ For Macintosh systems running Mac OS X, see Appendix B, “Configuring AMS (Mac OS X Only)” for information on configuring Apple Audio MIDI Setup and your MIDI devices.

- ◆ For Macintosh systems running Mac OS 9, see Appendix D, “Configuring OMS (Mac OS 9 Only)” for information on configuring Open Music System and your MIDI devices.

 *For information on configuring a MIDI control surface for use with Pro Tools, see the electronic PDF version of the Pro Tools MIDI Control Surfaces Guide (included with Pro Tools).*

### To connect MIDI devices:

- 1 Using standard 5-pin MIDI cables, connect the MIDI Out of the MIDI device or controller to the MIDI In of your Digi 001 I/O Box.
- 2 Connect the MIDI In of your MIDI device or controller to the MIDI Out of the Digi 001 I/O Box.
- 3 Connect the audio outputs of your device to the audio inputs of the Digi 001 I/O Box (or to an external mixer if you are using one).

 *If you have an external MIDI interface, you should not connect the MIDI ports of the Digi 001 to the MIDI ports of the MIDI interface. You can, however, use them both for connecting external MIDI devices. For example, connect a MIDI control surface to the Digi 001 and connect the rest of your MIDI devices to the MIDI interface.*

## chapter 6

# Working with Pro Tools LE

This overview of Pro Tools LE software introduces its main windows and features, and also includes a step-by-step overview of audio recording (see “Basic Recording” on page 56).

All features described in this chapter are explained fully in the *Pro Tools Reference Guide*. You can view an electronic PDF version of the *Reference Guide* by choosing it from the Pro Tools Application menu (Pro Tools 6) or the Pro Tools Help menu (Pro Tools 5). Refer to that guide and its index for more information on Pro Tools LE features.

---

## Session Basics

Pro Tools LE projects are created and saved as *sessions*. Sessions store all tracks, audio, MIDI, and other session information. Audio and fade files are stored in folders within the session folder.



Session file, Audio Files and Fade Files folders

## Starting a Session

To create a new session:

- 1 Launch Pro Tools LE.
- 2 Choose File > New Session.
- 3 In the New Session dialog, set the sample rate, bit depth, and other options for the new session.



New Session dialog

- 4 Select where you want to save your session. If you are using external hard drives with your Pro Tools system, make sure you select the appropriate drive in the New Session dialog.
- 5 Type a name for your session.
- 6 Click Save. The new session opens its Mix, Edit, and Transport windows (see Figure 11 on page 46).

## Main Windows

The Mix, Edit, and Transport windows are the main Pro Tools work areas. You can show any of these windows by choosing them from the Windows menu.

 Press **Control+Equals (=)** in Windows or **Command+Equals (=)** on Macintosh to switch between the Edit and Mix windows.

**Mix Window** Displays the Pro Tools mixer, with its familiar fader strip controls for track volume, pan, solo, mute, and signal routing.

**Edit Window** Displays tracks in the session along the Timeline, for editing of audio, MIDI, and automation data.

**Transport** Provides standard transport controls for Play, Stop, Rewind, Fast-Forward, Pause, and Record. The Transport window can also show Counter and MIDI Control displays.

## Rulers

Pro Tools LE provides several different rulers to select as the timebase for your session. Timebase Rulers, displayed along the top of the Edit window, include *Bars:Beats*, *Minutes:Seconds*, and *Samples*. The current timebase determines the format of the Main counter, and provides the basis for the Edit window Grid.

### To select a Timebase Ruler:

- Click the name of the ruler at the top left side of the Edit window (Bars:Beats, Minutes:Seconds, or Samples).



Figure 11. Main session windows

## Setting a Tempo

You can set the tempo for your session using Tempo Events, or using the MIDI tempo controls in the expanded Transport window.

### To insert a tempo event:

- 1 Choose Windows > Show Tempo/Meter.
- 2 At the top of the Tempo/Meter Change window, choose Tempo Change from the pop-up menu.

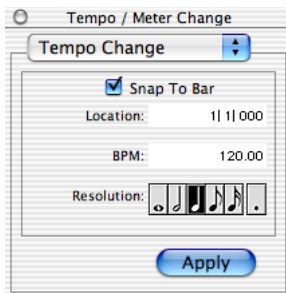

Tempo/Meter Change window

- 3 Enter the BPM value you will use for the session and set the Location to 1|1|000 (so the inserted tempo event replaces the default tempo).
- 4 To base the BPM value on a different note value (such as an eighth-note rather than the default quarter-note), select a note value.
- 5 Click Apply to insert the new tempo event.

## Using the Click Plug-In

### (Pro Tools 6.x Only)

The Click plug-in creates an audio click during session playback that you can use as a tempo reference when performing and recording. The Click plug-in receives its tempo and meter data from the Pro Tools application, enabling it to follow any changes in tempo and meter in a session.

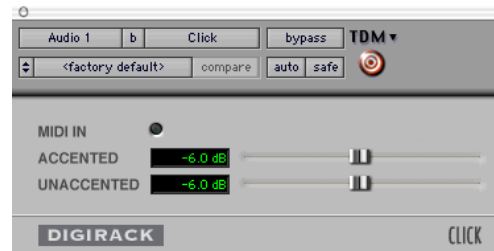

Click plug-in

### Click Parameters

**MIDI In LED** Illuminates each time the Click plug-in receives a click message from the Pro Tools application, indicating the click tempo.

**Accented** Controls the output level of the accent beat (beat 1 of each bar) of the audio click.

**Unaccented** Controls the output level of the unaccented beats of the audio click.

### To use the Click plug-in:

- 1 Choose MIDI > Click to enable the Click option (or enable the Click button in the Transport window).
- 2 Create a mono Auxiliary Input and insert the Click plug-in.
- 3 Select a click sound preset.

4 Choose MIDI > Click Options and set the Click and Countoff options as desired.

**⚠** *The Note, Velocity, Duration, and Output options in this dialog are for use with MIDI instrument-based clicks and do not affect the Click plug-in.*



Click Options dialog

 Refer to the Pro Tools Reference Guide for more information on configuring Click options.

5 Begin playback. A click is generated according to the tempo and meter of the current session and the settings in the Click Options dialog.

## Using an External MIDI Click

Pro Tools also provides a MIDI Click option that lets you use an external MIDI device to play a click. This feature can be turned on and off in the Transport window, and is configured from the MIDI Click Options dialog.

**To configure and enable an external MIDI click:**

- 1 Choose MIDI > Click Options.
- 2 Configure the click parameters as needed for your MIDI sound source.
- 3 Select the desired MIDI sound source from the Output pop-up menu and click OK.
- 4 During recording or playback, you can turn the Click on or off with the Metronome button in the MIDI Controls display of the Transport window.

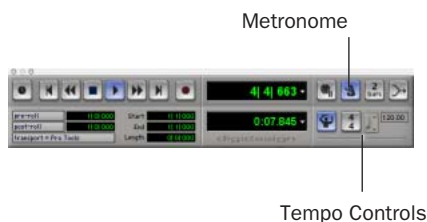

Click and Tempo Controls in the Transport window

## Saving Sessions

As you build a session by adding tracks and changing session controls, you will want to save your work. Pro Tools provides three ways to save sessions.

**To save a session:**

- Choose File > Save Session, Save Session As, or Save Session Copy In.

**Save Session** Saves the currently open session file, leaving it open for you to continue working.

**Save Session As** Creates a duplicate session file with the name you choose, and leaves the duplicate open for you to continue working. It does not create a new Audio Files or Fade Files folder. This can be useful if you want to experiment with different arrangements in the session without affecting the original session.

**Save Session Copy In** Saves copies of the session file and the files that you are using in the current session. This can be useful for creating a final copy of the session that does not include audio files or fades you are no longer using.

## System Resources and Settings

You can change specific Pro Tools system settings to optimize system performance.

### Playback Engine Dialog

The Playback Engine dialog lets you adjust system buffer sizes and allocate CPU processing power to Pro Tools.

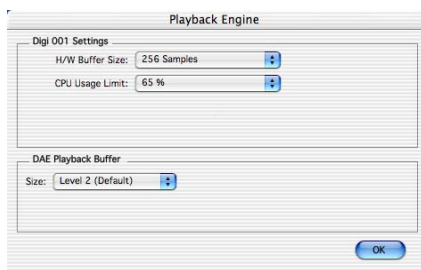

*Playback Engine dialog for Digi 001 system*

### To configure system resources:

- Choose **Setups > Playback Engine**. For more information, see “Configuring Pro Tools LE System Settings” on page 12 (Windows) or “Configuring Pro Tools LE System Settings” on page 22 (Macintosh).

### System Usage Window

The System Usage window displays information on CPU usage, so you can gauge your system’s processing capacity.

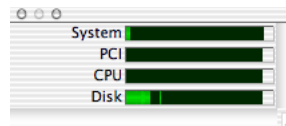

*Meters in the System Usage window*

### To view system resources and usage:

- Choose **Windows > Show System Usage**.

---

## Transport Controls

The Transport window provides access to all Pro Tools LE transport commands. Different transport controls can be displayed or hidden in this window.

### To show the Transport window:

- Choose Window > Show Transport Window.

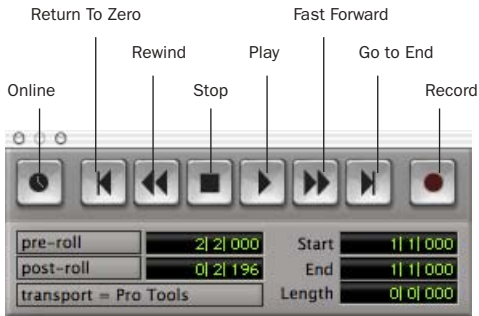

Transport window

### To configure the Transport window:

- Choose Display > Transport Window Shows and select view options.

In standard view, the Transport window provides Play, Stop, and other standard transport controls. The Expanded Transport window provides pre- and post-roll, start, end, and length indicators for Timeline selection, as well as the Transport Master selector.

The Transport window can also display the following MIDI controls: Wait for Note, Click, Countoff, MIDI Merge, Conductor, Meter, and Tempo.

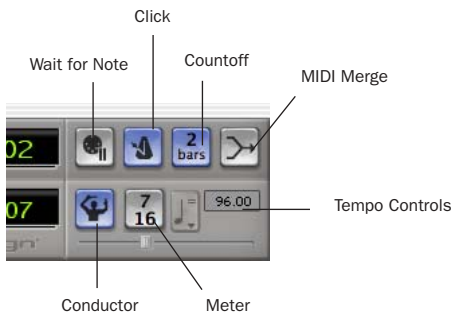

Transport window MIDI Controls

### To start and stop playback:

- 1 Click Play in the Transport window to begin playback.
- 2 Click Stop in the Transport window to stop playback.

 Press the Spacebar on your computer keyboard to start and stop playback.

 Pro Tools LE starts playing from the location of the cursor, or from the beginning of the current selection. The current setting of the Link Edit and Timeline Selection command in the Operations menu also affects playback. See the Pro Tools Reference Guide for more information.

---

## Navigating a Session

Pro Tools LE provides many ways to navigate in a session, including using the mouse or entering a location into one of the counters.

### To navigate to a location in the Edit window:

- 1 Select Operations > Link Edit and Timeline Selection.
- 2 Enable the Selector tool at the top of the Edit window by clicking it.

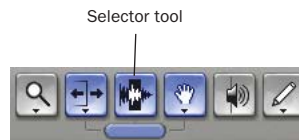

Edit tools in Edit window



**3** Click in a track or Timebase Ruler. The cursor appears at the selected location and the counters display the current time location.

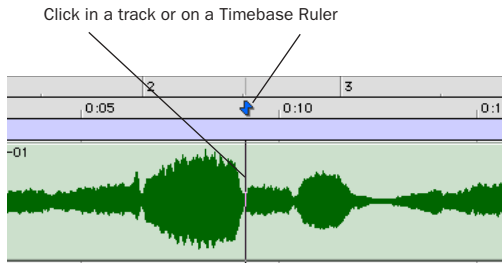

*Clicking with the Selector in the Edit window*

**To navigate using the counters:**

- 1 Click in the Main counter and enter a location using your computer keyboard.
- 2 Press Enter (Windows) or Return (Macintosh).



*Navigating with the Counter*

 Press the \* key on the numeric keypad as an alternative to clicking in the counter.

## Memory Locations

Memory Locations provide another way to navigate within sessions. Memory Locations appear as markers under the Timebase Rulers.

**To define a memory location:**

- 1 Press Enter on the numeric keypad while stopped or during playback.

In the New Memory Location window, you can define a marker, store a selection, or store any combination of the other available settings. These settings include track height, group enables, pre- and post-roll values, and track Show/Hide status.

- 2 Choose settings for the memory location and click OK.

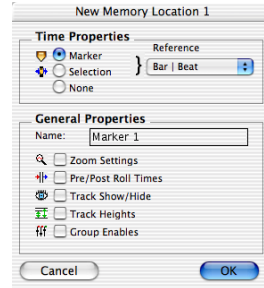

*New Memory Location window*

**To go to a stored Memory Location:**

- 1 Choose Windows > Show Memory Locations.
- 2 In the Memory Locations window, click the name of the memory location.

## Viewing and Zooming

When viewing tracks in the Edit window, you can adjust the height of tracks as well as zoom in vertically and horizontally using the Track Height selector and Zoom tools.



Zoom and Track Height tools in the Edit window

### To change track height:

- Click the Track Height Selector, and select a track height from the pop-up menu.

 You can apply many commands, including track height selection, to more than just a single track. Hold down the Alt key (Windows) or Option key (Macintosh) while performing an operation to apply it to all tracks. Hold down both the Shift and Alt keys (Windows) or Shift and Option keys (Macintosh) while performing an operation to apply it to all selected tracks.

### To Zoom in on any area of a track in the Edit window:

- 1 Click to select the Zoomer.
- 2 Click or drag with the Zoomer to zoom in horizontally for a track or Ruler.

### To zoom in or out incrementally:

- Click the appropriate Zoom button:
  - Left Arrow (Horizontal Zoom Out)
  - Right Arrow (Horizontal Zoom In)
  - Waveform and MIDI buttons, to increase or decrease vertical zoom of the appropriate track type (audio or MIDI)

Pro Tools also provides five Zoom preset buttons. You can use these to immediately return to established zoom levels; you can define the magnification level for each preset, on a session-by-session basis.

### To use a stored Zoom preset:

- Click the appropriate Zoom preset 1–5.

### To store a new Zoom preset definition:

- Control-click (Windows) or Command-click (Macintosh) a Zoom preset number to store the current horizontal and vertical Zoom to that preset.

## Using Memory Locations for Zoom Control

Pro Tools Memory Locations let you store many attributes with each marker or memory location, including Track Height and Zoom Settings. By creating Memory Locations that are neither Markers nor Selections, but have Track Height, Zoom Settings, or other options enabled, you can use Memory Locations to zoom in and out using just the numeric keypad.

## Tracks

Pro Tools LE lets you create audio and MIDI tracks for audio and MIDI recording, submixing, routing, automating, and editing.

Pro Tools provides four types of tracks: audio tracks, Auxiliary Inputs, Master Faders, and MIDI tracks. Audio tracks, Auxiliary Inputs, and Master Faders can be mono or stereo.

**Audio Tracks** Record and play back audio to and from hard disk, monitor audio input when record-enabled, and edit audio regions

**Auxiliary Inputs** Audio mixer channels used for input, routing, and submixing

**Master Faders** Provide master channel controls and options for any Output or Bus path

**MIDI Tracks** Record, play back, and edit MIDI data

### To create a new track:

- 1 Choose File > New Track.



*New Track dialog*

- 2 Specify the number of tracks, track type, and mono or stereo (for all types except MIDI).
- 3 Click Create.

In the Mix window, audio tracks, Auxiliary Inputs, Master Faders, and MIDI tracks appear as vertical channel strips. Track type is indicated by the Track Type icons just below the faders.



### Tracks in the Mix window

In the Edit window, tracks are displayed horizontally along the Timeline. The area in which audio appears for each track is the Playlist.

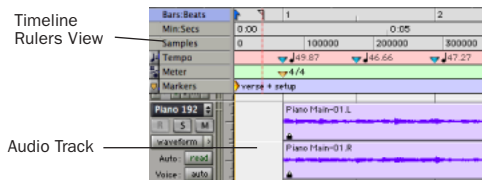

### Timeline Rulers and a stereo audio track in the Edit window

Audio tracks, Auxiliary Inputs, Master Faders, and MIDI tracks can be automated. (See “Mix Automation” on page 69 for more information.)

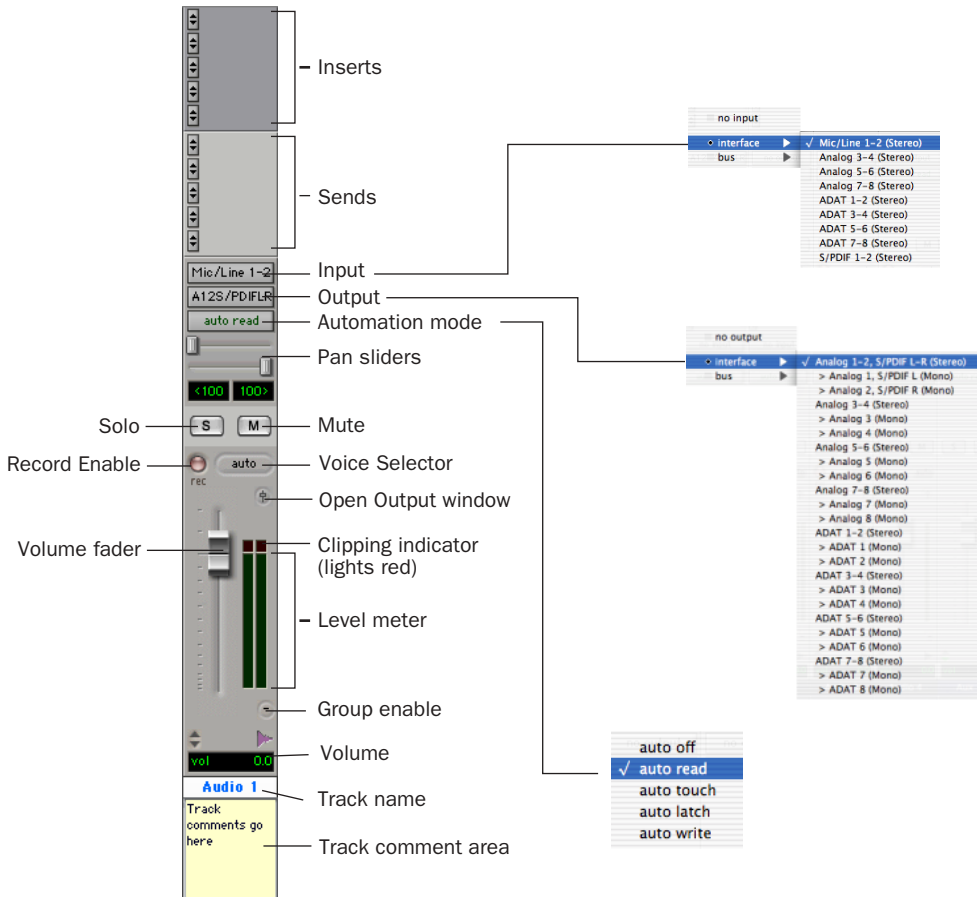

Figure 12. Stereo audio track in the Mix window

## Audio Tracks

Audio tracks, Auxiliary Inputs, and Master Faders share many identical controls. Figure 12 shows the controls found in an audio or Auxiliary Input track.

Master Faders provide all the same features as audio tracks and Auxiliary Inputs, with the following exceptions:

**Input Selector** A Master Fader's output assignment determines its input, or source.

**Sends** Master Faders do not provide sends. To send an output to another destination, use an Auxiliary Input.

## MIDI Tracks

MIDI tracks provide track volume, solo, and mute, in addition to MIDI input, output, channel, and program (patch) controls. MIDI volume, mute, and pan can also be automated using Pro Tools automation features (see "Mix Automation" on page 69 for more information).

## Regions Lists

All regions that are recorded, imported, or created by editing appear in the Audio and MIDI Regions Lists. Regions can be dragged from either list to tracks and arranged in any order. Audio regions can also be auditioned from the Regions Lists by Alt-clicking (Windows) or Option-clicking (Macintosh) the audio region name.

The Regions List pop-up menus provide many useful features for managing regions and files (such as sorting, selecting, importing, or exporting files).

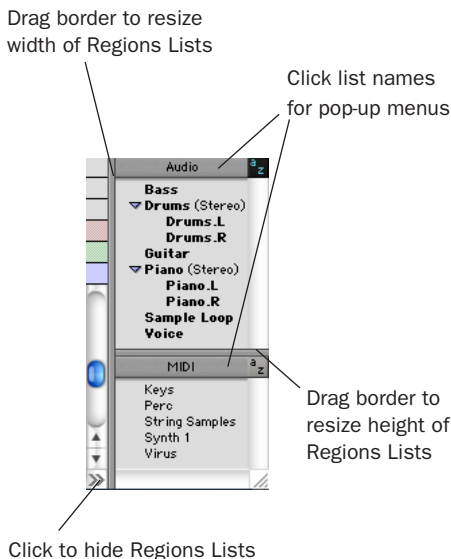

### Audio and MIDI Regions Lists

 For more information on Regions Lists, refer to the Pro Tools Reference Guide.

The imported audio file appears in the Audio Regions List. From there you can drag the region to a track in your session.

## Importing Audio

Pro Tools LE lets you import existing audio files from disk, as well as import tracks from an audio CD (Macintosh only). This is very useful if you have audio files you've already recorded to disk or if you are working with CD-based sample libraries that you want to use in a new session.

### To import audio files or regions from disk:

■ Choose File > Import Audio to Track to import files and regions to new audio tracks (they will also appear as regions in the Audio Regions List).

– or –

Choose Import Audio from the Audio Regions List pop-up menu to import files and regions to the Audio Regions List only.

 For more information on importing audio into sessions, refer to the Pro Tools Reference Guide.

### To import a CD audio track (Pro Tools 6.x):

- 1 Insert an audio CD into your CD-ROM drive.
- 2 Choose Movie > Import Audio From Other Movie.
- 3 Locate and select the audio track to be imported, then click Open.
- 4 In the Track Import Window, click OK.
- 5 Navigate to a destination for the imported audio, and click Choose.

Pro Tools converts the CD audio track to the session's audio file format, bit depth, and sample rate, and saves it on your hard drive.

 DigiBase provides additional importing options for Pro Tools LE version 6.x. See the DigiBase Guide for more information.

### To import a CD audio track (Pro Tools 5.1.1):

- 1 Insert an audio CD into your CD-ROM drive.
- 2 Choose Movie > Import Audio From Other Movie.
- 3 On the audio CD, locate and select the audio track to be imported, then click Convert.
- 4 In the Save dialog, click Options.
- 5 In the Options dialog, select the sample rate, bit resolution, and channel format (mono or stereo) for the imported audio.

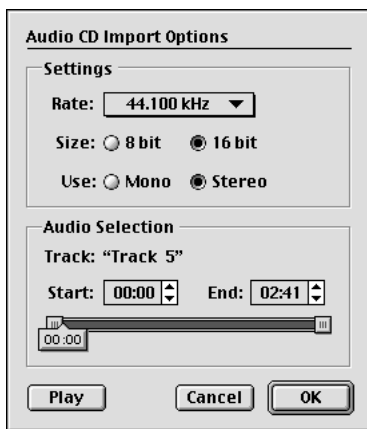

Audio CD Import Options dialog

6 At the bottom of the Options dialog, set the range of the CD track to be imported by adjusting the Start and End times, then click OK.

To audition a track before you import it, use the Play and Stop buttons. Adjust playback volume with the vertical slider. To navigate to a particular location in the track, drag the horizontal slider.

7 When you are ready to import the audio, click OK.

8 Specify a destination on an audio drive for the imported audio track and click Save. Pro Tools imports the CD audio track as a QuickTime movie and writes it to your audio drive.

9 When the Track Import window appears, click OK.

Pro Tools converts the audio track to your session's sample rate and bit resolution and imports the selected audio tracks into the Audio Regions List. From there you can drag the regions to existing tracks.

---

## Basic Recording

This section describes how to record audio and MIDI into Pro Tools LE.

### Routing Audio to a Track

To route audio to a track:

- 1 Verify the connections to your instruments. Refer to Chapter 5, "Connecting Your Studio" for more information about connecting instruments to Digi 001.

2 Create a new track to record on by choosing File > New Track. Specify 1 Mono Audio Track and click Create.

3 In the Mix window, click the Input Selector on the new track.

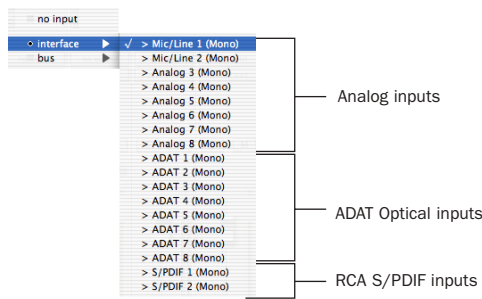

#### Routing an input to a mono track

From the pop-up menu, select the input you want to record. For example, select Mic/Line 1 if your audio source is plugged into the Mic/Line 1 input on the front of the Digi 001.

## Setting Digi 001 Input Levels

Digi 001 input levels for analog inputs 1 and 2 are adjusted using the Gain knobs on the front panel of the Digi 001 I/O Box for each channel. Input levels for analog inputs 3–8 are software-adjustable to accommodate a variety of equipment output levels.

For line level or instrument sources, set the device's output volume to the highest level possible without distortion, to maximize the signal going into Pro Tools.

The key to setting proper input levels is to get a signal as loud as possible without overloading the Digi 001 inputs or creating digital clipping. Signals that get close to the top of the meter in Pro Tools LE use more of the full bit range (the

16 or 24 bits that make up each audio sample). The more you are able to maximize this bit range without clipping, the better your sound quality.

 *Digital clipping occurs when you feed a signal to an audio device that is louder than the circuitry can accept. Watch the meters in Pro Tools while adjusting input levels to prevent clipping.*

 *For best signal-to-noise performance, set the Digi 001 input gain to +4 dBu when recording devices that provide this output level.*

#### To adjust input gain on the Digi 001 (Mic/Line inputs 1–2):

- 1 Connect your instrument or microphone to the input on the front of the Digi 001 I/O Box.
- 2 If the microphone requires phantom power, apply phantom power by pressing the 48V switch on the front of the Digi 001 I/O Box.
- 3 Choose File > New Track and specify 1 Mono Auxiliary Input, then click Create.
- 4 If necessary, Alt-click (Windows) or Option-click (Macintosh) the Auxiliary Input fader to set the fader to unity gain (0 dB).
- 5 Set the track input to the correct Digi 001 input channel (Mic/Line 1 or Mic/Line 2).
- 6 Play the instrument or sound source at the volume you will record.

7 Adjust the input gain for the channel using the gain knob on the front of the Digi 001 I/O Box. Increase or decrease gain until you are able to achieve maximum signal level without clipping. Typically such levels are in the yellow area of the track's meter.



Digi 001 Input Gain control (Mic/Line Inputs 1–2)

**To adjust input gain on the Digi 001 (Analog inputs 3–8):**

- 1 Connect your instrument or device to an input (for a mono device) or inputs (for a stereo device) on the back of the Digi 001 I/O Box.
- 2 Choose File > New Track and specify 1 Auxiliary Input, then click Create. The Auxiliary Input can be either mono or stereo depending on the device you are monitoring.
- 3 If necessary, Alt-click (Windows) or Option-click (Macintosh) the Auxiliary Input fader to set the fader to unity gain (0 dB).
- 4 Set the track input to the correct Digi 001 input channel (Analog 3–8).
- 5 Choose Setups > Hardware Setup.
- 6 On Mac OS 9, click Other Options.

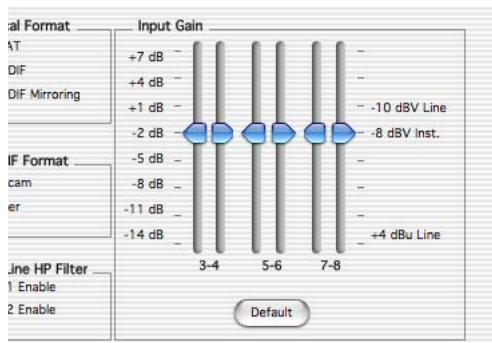

Digi 001 Input Gain controls (Inputs 3–8)

7 Drag the Input Gain slider of each channel to match the output level of the connected instrument. Refer to the instrument manufacturer's documentation for details on the output level of the device. If you do not know the output level, use the default input trim level, then fine-tune the Input Gain level using the procedure below.

8 Continue to fine tune the input gain, below.

**To fine-tune the input gain on the Digi 001 (Analog inputs 3–8):**

- 1 With the Input Gain sliders visible, play the instrument at the volume you will record.
- 2 Note where the instrument output signal registers on the on-screen meters in the Mix window. Good levels are in the yellow range of the Pro Tools LE track meters. If the levels hit the red, they are clipping, and you should lower the input gain.
- 3 If the meters are not in the yellow range, and they are not clipping, increase the input gain by raising the volume slider for the appropriate input in the Hardware Setup dialog.
- 4 Repeat the previous steps for each input until you have the maximum signal level without clipping.
- 5 On Mac OS 9, click Done to close the Other Options dialog.
- 6 Click OK to close the Hardware Setups dialog.

**⚠** Gain for digital inputs cannot be adjusted in Pro Tools LE. Adjust gain at the source.



## Mic/Line High-Pass Filter

Digi 001 includes a high-pass filter set at 60 Hz. This filter can be useful for filtering out low-end rumble from a noisy recording environment or microphone handling, or AC noise.

### To use the high-pass filter on analog input 1 or 2:

- 1 Choose Setups > Hardware Setup.
- 2 On Mac OS 9, click Other Options.
- 3 Select the Mic/Line HP Filter option for the required inputs.
- 4 On Mac OS 9, click Done to close the Other Options dialog.
- 5 Click OK to close the Hardware Setup dialog.

## Recording an Audio Track

### To record an audio track:

- 1 Click the Record Enable button for a track, assign its input, and set the input levels appropriately.
- 2 Choose Windows > Show Transport to display the Transport window. Click Return To Zero to start recording from the beginning of the session. You can also record according to a selection or from the cursor location in the Edit window.
- 3 Click Record in the Transport window to enable recording.
- 4 Click Play or press the Spacebar to record on all record-enabled tracks.
- 5 Record your performance.
- 6 Click Stop in the Transport window or press the Spacebar when you are done recording.

### To play back a recorded track:

- 1 Click the track's Record Enable button a second time to take it out of record mode.
- 2 Click Play in the Transport window or press the Spacebar to start playback.
- 3 Click Stop in the Transport window or press the Spacebar to stop playback.

## Recording To and From Digital Devices

The Digi 001 I/O Box provides S/PDIF (RCA) connectors for digital input and output. The Digi 001 PCI card also provides optical input and output so you can digitally transfer as many as eight tracks at a time to or from an ADAT.

### Setting Digital Format and Clock Source

Before recording from a digital source, make sure you have enabled the appropriate Digital Format in the Hardware Setup dialog. For more information, see “Recording a Digital Source” on page 15 (Windows) or “Recording a Digital Source” on page 26 (Macintosh).

### Recording To and From an ADAT

You can use Digi 001 to interface with an ADAT, either to record tracks from an ADAT into Pro Tools LE for editing, or to record tracks from Pro Tools LE to an ADAT.

## Using Output Pairs

Because of the way that outputs function in Pro Tools LE, each track looks for a stereo output pair. In order to record to eight ADAT tracks, you have to send four pairs of Pro Tools LE tracks (each pair panned hard left and right) to Digi 001's four pairs of ADAT Optical Digital outputs.

 For detailed information on connecting an ADAT to Digi 001, see "Connecting an ADAT to Digi 001" on page 43.

### To record ADAT tracks into Pro Tools LE:

- 1 Connect the Optical Out connector from your ADAT deck to the Optical In connector on the Digi 001 PCI card.
- 2 Open or create a session in Pro Tools LE.
- 3 Record enable up to eight audio tracks.
- 4 For each track, click its Input Selector and assign ADAT Optical Inputs 1–8.
- 5 Verify that the Clock Source is set to Optical in the Hardware Setup dialog, and that the Optical Format is set to ADAT (see "Recording a Digital Source" on page 15 for Windows or "Recording a Digital Source" on page 26 for Macintosh).
- 6 Click Record in the Transport window.
- 7 Click Play in the Transport window to begin recording, then press Play on the ADAT.
- 8 When playback from the ADAT deck is finished, click Stop in the Transport window, or press the Spacebar.

### To record Pro Tools LE tracks to an ADAT:

- 1 Connect the Optical Out connector on your Digi 001 PCI card to the Optical In connector on the ADAT deck.

- 2 Open the session you want to record to ADAT.

- 3 Record enable up to eight audio tracks on the ADAT.

- 4 In Pro Tools, pan the four pairs of tracks you want to record to ADAT so that each pair is panned hard stereo (one track of each pair is panned all the way left, and the other is panned all the way right).

- 5 Route each track pair to a separate Optical output pair by selecting from the Output pop-up menu for each track.

- 6 Verify that the Clock Source is set to Internal in the Hardware Setup dialog (see "Pro Tools Hardware Settings" on page 14 for Windows or "Pro Tools Hardware Settings" on page 24 for Macintosh).

- 7 Start recording on the ADAT, then click Play in the Pro Tools LE Transport window. When playback is complete, stop both systems.

## Monitoring Latency and Recording

Because Pro Tools LE uses the host processor in your computer for audio processing, playback, and recording, there is a small amount of audio delay, or latency, when monitoring audio through the system. You can set the latency to a lower value when you are recording and monitoring through Digi 001, and to a higher value when you are mixing and working with more plug-ins.

Latency is controlled by the Hardware Buffer Size setting, and is displayed in samples. The recommended setting for listening back to audio is 512–1024 samples. For recording, when monitoring through Digi 001, the recommended setting is 128–256 samples.

**To set the Hardware Buffer Size for record or playback:**

- 1 Choose **Setups > Playback Engine**.

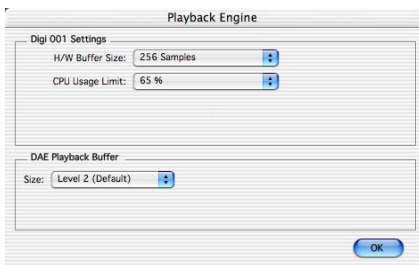

*Playback Engine dialog for Digi 001 system*

- 2 Choose a setting from the **H/W Buffer Size** pop-up, then click **OK**.

## Low Latency Monitoring

Pro Tools LE includes a feature called Low Latency Monitoring for Digi 001 systems. This feature uses a built-in mixer on the Digi 001 PCI card to record and monitor up to 16 inputs (8 analog and 8 ADAT) with extremely low latency. This mode can be very useful for recording multiple instruments at the same time.

To use Low Latency Monitoring, tracks must be record-enabled, assigned to an actual audio input (not a bus), and assigned to Outputs 1 or 2.

**To enable Low Latency Monitoring:**

- **Select Operations > Low Latency Monitoring.**

When Low Latency Monitoring is enabled, any plug-ins and sends assigned to record-enabled tracks (routed to Outputs 1–2) are automatically bypassed, and must remain bypassed. Also, these tracks will not register on meters for Master Faders.

## Recording MIDI

**To configure a new MIDI track for recording:**

- 1 (Macintosh Only) Choose **MIDI > Input Devices** and make sure your input device is selected in the MIDI Input Enable window.
- 2 Choose **File > New Track** and specify 1 MIDI Track, then click **Create**.
- 3 In the Mix window, click on the track's MIDI Device/Channel Selector and assign a device and channel from the pop-up menu.

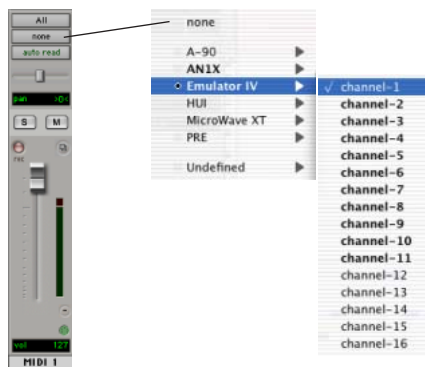

*MIDI Device/Channel Selector*

- 4 You can assign a default program change to the track by clicking on the **Program** button in the Mix window and making the necessary selections for program and bank select, and then clicking **Done**. Default program changes are sent when playing a track.
- 5 In the Mix window, record enable the MIDI track.
- 6 Make sure **MIDI > MIDI Thru** is selected, then play some notes on your MIDI controller. The MIDI instrument assigned to the track should sound, and the track's meters should register MIDI activity.

### **To record onto a MIDI track:**

- 1** Verify that the MIDI track you want to record to is record-enabled and receiving MIDI.
- 2** In the Transport window, click Return To Zero to start recording from the beginning of the session. You can also record according to a selection or from the cursor location in the Edit window.
- 3** Click Record in the Transport window.
- 4** Click Play in the Transport window or press the Spacebar to begin recording.

– or –

If using Wait for Note, the Play, Record, and Wait for Note buttons flash. Recording begins when the first MIDI event is received.

– or –

If using Countoff, click Play. The Record and Play buttons flash during the Countoff, then recording begins.

- 5** Play your MIDI instrument.
- 6** When you have finished recording, click Stop in the Transport window, or press the Spacebar. The newly recorded MIDI data appears as a MIDI region on the track in the Edit window, as well as in the MIDI Regions List.

### **To play back a recorded MIDI track:**

- 1** Click the Record Enable button to take the MIDI track out of Record mode.
- 2** In the Transport window, click Return To Zero to play back from the beginning of the track. You can also play back according to a selection or from the cursor location in the Edit window.
- 3** Click Play in the Transport window to begin playback. The recorded MIDI data plays back through the track's assigned instrument and channel.

### **Monitoring MIDI Instruments Without a Mixer**

To monitor your MIDI instrument's analog output, you can use an Auxiliary Input. Auxiliary Inputs function as inputs for both internally bussed signals and external audio sources.

#### **To configure an Auxiliary Input for MIDI monitoring:**

- 1** Connect the MIDI instrument's audio output to the appropriate inputs on your Digi 001.
- 2** Choose File > New Track and specify 1 mono or stereo Auxiliary Input, then click Create.
- 3** Click the Input selector of the Auxiliary Input channel and choose the input to which your MIDI instrument is connected.
- 4** Click the Output selector of the Auxiliary Input channel and choose an output.
- 5** Adjust the level of the Auxiliary Input with its volume fader.

## Editing

Pro Tools LE provides several tools for editing audio and MIDI. In the Edit window, audio and MIDI tracks can be edited into regions or repeated in different locations, to create loops, re-arrange sections or entire songs, or to assemble tracks using material from multiple takes.



*Edit modes and tools (Slip mode, Smart Tool enabled)*

Audio and MIDI editing are typically used to:

- Fix or replace mistakes
- Re-arrange songs and projects
- Clean up track timing and rhythm by aligning hits to Grid values like bars and beats
- Create final tracks using selections from multiple takes (also known as *comp tracks*).

### Edit Modes

Pro Tools LE has four Edit modes: Shuffle, Spot, Slip, and Grid. The Edit mode is selected by clicking the corresponding button in the upper left of the Edit window.



*Edit mode buttons*

 You can also press F1 (Shuffle), F2 (Slip), F3 (Spot), and F4 (Grid) to set the Edit mode.

The Edit mode affects the movement and placement of audio and MIDI regions (and individual MIDI notes), how commands like Copy and Paste function, and also how the various edit tools (Trimmer, Selector, Grabber, and Pencil) work.

 For detailed descriptions of Edit modes, see the *Pro Tools Reference Guide*.

### Edit Tools

Pro Tools LE has seven Edit tools: Zoomer, Trimmer, Selector, Grabber, Scrubber, Pencil, and Smart Tool. Select an Edit tool by clicking it in the Edit window. The Zoomer, Trimmer, Grabber, and Pencil tools have multiple modes, which you can select from a pop-up menu when you click the tool.

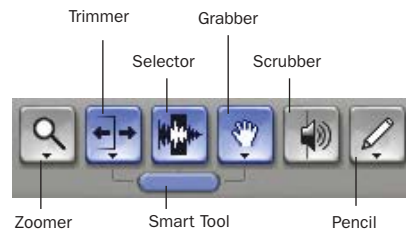

*Edit tools in Edit window*

 Press the **Escape** key to toggle through the Edit tools.

 For detailed descriptions of the Edit Tools, refer to the *Pro Tools Reference Guide*.

## Editing Regions

The Edit tools in Pro Tools LE are used to edit regions in the Edit window. A region is a piece of audio or MIDI data that can also have associated automation data. For example, a region could be a loop, a guitar riff, a verse of a song, a sound effect, a piece of dialog, or an entire sound file. In Pro Tools, regions are created from audio or MIDI files, and can be arranged in audio and MIDI track playlists.

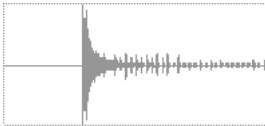

Audio region

### Trimming Regions

After recording an audio track, you will have an audio region on that track. If there is some silence at the beginning of the region, or there is some extra audio at the end of the region, you can use the Trimmer tool in Slip mode to shorten the beginning or end of the region.



Audio region on a track

#### To trim an audio region:

- 1 Select Slip mode.
- 2 Select the Trimmer tool.
- 3 Move the cursor near the beginning of the audio region (notice the cursor changes to a “[”).



Trimming the beginning of a region

- 4 Click at the beginning of the region and drag right to shorten the region.

- 5 Move the cursor near the end of the audio region (notice the cursor changes to a “]”).



Trimming the end of a region

- 6 Click at the end of the region and drag left to shorten the region.



The trimmed region

You can also extend a region using the Trimmer tool if there is audio data beyond the current boundaries of a region. If extending the region's beginning, drag to the left; if extending the region's end, drag to the right.

### Arranging Regions

There are many ways to edit and arrange regions; the following example demonstrates how you might create and arrange a drum loop to compose a rhythm track.

#### To create and arrange a rhythm sequence:

- 1 Open or create a session in Pro Tools LE.
- 2 Specify the session meter (MIDI > Change Meter) and tempo (MIDI > Change Tempo).
- 3 Select Grid mode.
- 4 Prepare to record using a MIDI click (see “Using the Click Plug-In” on page 47 or “Using an External MIDI Click” on page 48).

**5** Record a drum track (see “Recording an Audio Track” on page 59) keeping in mind that you want to use only the best bar (measure). Your recording should fit the grid at the specified tempo and meter.

– or –

Import an existing audio file, such as a drum loop from a sample library, and place it on an audio track (see “Importing Audio” on page 55).

**6** Drag on the waveform with the Selector to make a one-bar selection. Note that the selection snaps to the specified grid.

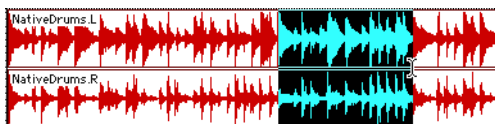

*Making a selection in Grid mode*

**7** Create a new audio track (File > New Track).

**8** From the Grabber pop-up menu, select the Separation Grabber tool.

**9** With the Separation Grabber tool, drag the selection to the beginning of the new audio track. A new region is created and appears at the beginning of the new track.

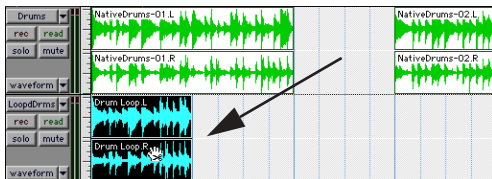

*Dragging a selection with the Separation Grabber tool*

**10** With the new region still selected, choose Edit > Repeat.



*Repeat dialog*

**11** In the Repeat dialog, enter a number of repeats, and click OK.

You now have a new rhythm track with a “looped” (repeated) phrase. You can use these editing tools to do much more advanced and involved editing of regions. For example, you could separate beats or “hits” into individual regions and rearrange them in Grid or Shuffle mode as a way of coming up with new and interesting rhythms.

## Playlists and Nondestructive Editing

Playlists let you create and retrieve multiple versions of track edits. A playlist can be a complete take, an overdub, or an arrangement of selections from multiple takes. You can duplicate playlists to save edits in their current state, then continue making additional edits to the new playlist knowing you can always go back to the previous version.

### To create multiple playlists for editing:

- 1 Start with a track on which you want to try different edits.
- 2 From the Playlist Selector pop-up menu, choose Duplicate.

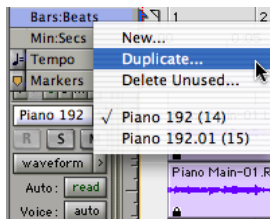

*Duplicating a playlist*

- 3 Name the duplicated playlist and click OK.
- 4 Make your first series of edits.
- 5 Return to the original playlist by selecting it from the Playlist Selector pop-up menu.

6 Repeat steps 2–5 for any further edits.

In this way, you can try out different edits of a track, and switch back and forth between playlists for comparison.

---

## Mixing

The Pro Tools LE mix environment provides many familiar channel strip controls for setting volume, pan, solo, and mute. Mixer and I/O controls can be shown in both the Mix and Edit windows.

**To view the Mix window:**

- Select Windows > Show Mix.



*Press Control+Equals (=) in Windows or Command+Equals (=) on Macintosh to switch between the Edit and Mix windows.*

### Using Channel Strip Controls

**Volume** Increase or decrease the track level by dragging its Volume fader up or down.

**Pan** Pan a track left or right in the mix by dragging its Pan slider left or right.

**Solo** Solo a track (muting all other tracks) by clicking its Solo button.

**Mute** Mute a track by clicking its Mute button.

## Basic Signal Routing

Signal routing is accomplished by assigning track inputs and outputs. Audio track inputs can be from any hardware input. Once recorded, an audio track's input is its audio file on disk. Auxiliary Inputs can be any hardware input or internal mix bus. For all types of audio tracks, outputs can be routed to any hardware output or internal bus send.

Together, these signal routing features let you set up virtually any mixer architecture for your projects, including submixing, and sends and returns for effects processing.

### Send and Return Submixing for Effects Processing

When you are submixing for reverb, delay, and similar effects processing, you can use sends and Auxiliary Inputs to achieve traditional send/return bussing. You can use a real-time plug-in (see "Plug-Ins" on page 69) or a hardware I/O insert (see "Using External Effects Devices" on page 40) as a shared resource for all tracks included in a submix. The wet/dry balance in the mix can be controlled using the track faders (dry level) and Auxiliary Input fader (wet, or effect return level).



## Creating a Send

Pro Tools LE provides up to five sends per audio track. A send can be mono or stereo, routing to an output or one of 16 internal bus paths.

### To assign a send on a track:

- 1 Make sure Sends View is enabled in the Mix window (Display > Mix Window Shows > Sends View).
- 2 Click the Sends button on an audio track and choose a path from the pop-up menu.

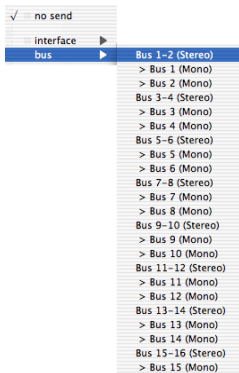

### Assigning a send to a stereo bus path

- 3 Set the output level of the send. You can set the send level to zero by Alt-clicking (Windows) or Option-clicking (Macintosh) the send fader.

 You can configure the default level for new sends to be  $-\infty$  or at unity gain (0 dB) by enabling or disabling the Sends Default To “ $-\infty$ ” option under the Operation Preferences.

## Creating a Return

Auxiliary Inputs can be created to act as return channels for busses, as well as for inputs from hardware sources.

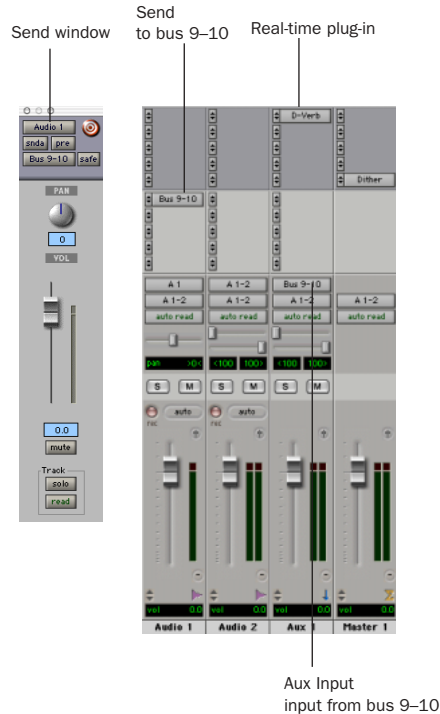

### Audio and Auxiliary Input tracks configured for a send and return

### To create a return:

- 1 Choose File > New Track and specify 1 mono or stereo Auxiliary Input, then click Create.
- 2 Click the Input Selector of the Auxiliary Input and set it to the bus path you assigned to the sends on the source tracks.
- 3 Click the Output Selector of the Auxiliary Input and choose an output path.

## Master Faders

Master Faders are used as output and bus masters, and can control any mono or stereo output or bus path in a session. You can then use the controls on the Master Fader to control the volume, solo and mute, or apply inserts to those paths.

When you are mastering your final mix, it is recommended that you use a dither plug-in on the Master Fader controlling your main outputs (see “Using Dither on Mixdown” on page 71).

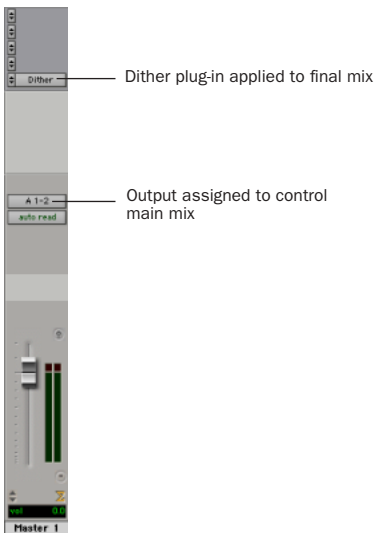

*Master Fader controlling main outputs*

### To create a Master Fader:

- 1 Choose File > New Track and specify 1 mono or stereo Master Fader track, then click Create.
- 2 In the Mix window, click the Master Fader's Output Selector and choose the output path that you want to control. You can choose either outputs or internal busses.

### To use a Master Fader as a master stereo volume control for all tracks in a session:

- 1 Choose File > New Track and specify 1 stereo Master Fader track, then click Create.
- 2 Set the outputs of all audio tracks in the session to outputs 1-2 and set the panning of each track.
- 3 Set the output of the Master Fader to your main output path (outputs 1-2).

---

## Plug-Ins

Plug-ins provide EQ, dynamics, delays and many other types of effects processing.

Plug-ins function either in real time or in non-real time. RTAS plug-ins are nondestructive effects, which are inserted on tracks to process audio in real time—just like an external hardware processor (during playback). AudioSuite plug-ins, on the other hand, are destructive effects that process audio files on disk in non-real time.

Real-time plug-ins are assigned to tracks from the Inserts view in the Mix or Edit windows. Once assigned to a track, plug-ins appear in the track's Inserts view, and can be opened by clicking the Insert button.

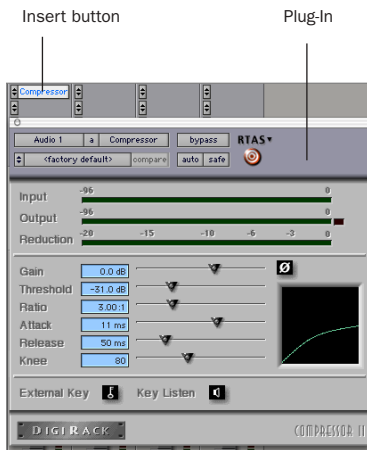

### Compressor plug-in

#### To insert a real-time plug-in on a track:

- 1 Make sure the Inserts View is shown in the Mix or Edit window.
- 2 Click the Insert Selector on the track and select the plug-in that you want to use.

Pro Tools LE comes with a complete set of Digi-Rack plug-ins, and many more are available from Digidesign and our Development Partners.

 For more information about plug-ins, see the *DigiRack Plug-Ins Guide*, the *Digidesign Plug-Ins Guide*, and the *Plug-Ins* chapter of the *Pro Tools Reference Guide*.

---

## Mix Automation

Mix automation lets you record, or *automate*, changes to track and send levels, mutes, pan, and plug-in parameters. MIDI tracks provide track volume, pan, and mute automation only.

#### To write automation:

- 1 In the Automation Enable window (Windows > Show Automation Enable), enable an automation *type* (volume, pan, mute, send level, send pan, send mute, or any plug-in automation).
- 2 Select an automation *mode* for the tracks to be automated (Write, Touch, or Latch mode).
- 3 Start playback and begin writing automation by adjusting faders and other controls during playback. Pro Tools LE remembers all moves performed on enabled parameters.

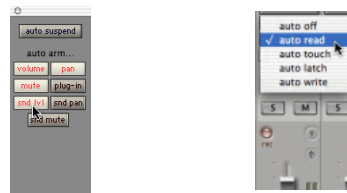

Enabling automation (left) and choosing a track Automation mode (right)

Once written, automation can be re-written or displayed and edited graphically in the Edit window.

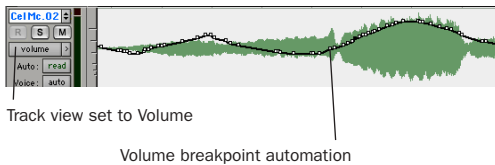

### Volume automation in a track in the Edit window

 For more information on using automation, see the *Pro Tools Reference Guide*.

## Mixing with a Control Surface

Rather than mixing with a mouse—adjusting one fader at a time—you might find using a MIDI control surface (such as Motor Mix from CM Labs) or an Ethernet control surface (such as Control|24) for mixing to be much more effective. The Digi 001's MIDI ports provide an excellent interface for MIDI control surfaces.

 For more information on using a MIDI Control Surface, see the *MIDI Control Surfaces Guide*. For more information on using Control|24, see the *Control|24 Guide*.

---

## Final Mixdown

The Bounce to Disk command lets you write a final mix to disk, create a new loop, print effects, or bounce any submix. Once you have bounced your final mix to disk, you can use another program to burn the resulting file to Compact Disc.

When you bounce a track to disk, the bounced mix includes the following:

**Audible Tracks** All audible tracks are included in the bounce. Any muted tracks do not appear in the bounce. If you solo a track or region, only the soloed elements appear in the bounced mix.

**Automation** All read-enabled automation is played back and incorporated in the bounced mix.

**Inserts and Sends** All active inserts, including real-time plug-ins and hardware inserts, are applied to the bounced mix.

**Selection or Track Length** If you make a selection in a track, the bounced mix will be the length of the selection. If there is no selection in any track, the bounce will be the length of the longest audible track in the session.

### To Bounce to Disk:

- 1 Choose File > Bounce to Disk.
- 2 Select any mono or stereo output or bus path as the source for the bounce.
- 3 Select the File Type (such as WAV), Format (such as mono or stereo), Resolution (such as 16-bit), and Sample Rate (such as 44.1 kHz).
- 4 Click Bounce.

## Using Dither on Mixdown

You should use a dither plug-in when using the Bounce To Disk command, or when mastering to an external device. Bounce to Disk does *not* automatically apply dither. To dither a bounce file, insert an included Digidesign Dither plug-in, or another dither plug-in, on a Master Fader assigned to the bounce source path. Master Faders are often preferable to Auxiliary Inputs because Master Fader inserts are post-fader (which is better for dither applications).

 *For more information on using dither, refer to the Pro Tools Reference Guide.*



# Windows System Optimizations

When installing Pro Tools on Windows XP, there are many system variables that affect performance. If you have followed all the Windows configuration instructions in Chapter 2, “Windows Configuration” and are still experiencing problems, try the following troubleshooting suggestions.

 *Norton Ghost is highly recommended, as it lets you save your system in a working state and easily revert to that state should you accidentally disable anything that your computer needs.*

---

## Troubleshooting

### Blue Screen at Startup

If, after installing Pro Tools LE and QuickTime, your computer crashes with a blue screen, use Add/Remove Programs to uninstall Pro Tools LE and QuickTime. Then, repeat the installation instructions in “Installing Pro Tools LE” on page 10.

---

## Advanced Settings

The following system optimizations may help Pro Tools perform better on some systems. It is recommended that you only try these optimizations if necessary, as they may disable or adversely affect the functionality of other programs on your system.

### Disabling Network Cards

If applicable, disable any networking cards (other than a 1394 “FireWire” card that you might use to connect an external drive to your system).

#### To disable a network card:

- 1 Right-click My Computer and choose Manage.
- 2 Under System Tools, select Device Manager.
- 3 In the Device Manager window, double-click Network adapters, then double-click the Network Adapter card you want to disable.
- 4 Under the General tab, choose “Do not use this device (disable)” from the Device Usage pop-up menu, and click OK.
- 5 Close the Computer Management window.

## Processor Scheduling

### To Adjust Processor Scheduling Performance:

1 Choose Start > Control Panel.

2 In Classic View, click System.

– or –

In Category View, click Performance and Maintenance, then click System.

3 Click the Advanced tab.

4 Under the Performance section, click the Settings button.

5 Select the Advanced tab.

6 Under the Processor scheduling section, select the “Adjust for best performance of background services” option.

7 Under the Memory Usage section, select the System cache option.

8 Click OK twice. You will need to restart your computer for the changes to take effect.

### Startup Items

The fewer items in use by your computer, the more resources are available for Pro Tools LE. Some startup applications may be consuming unnecessary CPU resources, and should be turned off.

Be very careful when disabling startup items, including (but not limited to) the following:

- Portable media serial number (required for applications that utilize a copy protection key)
- Plug and play
- Event log
- Cryptographic services
- DHCP Client, TCP/IP Net BIOS, and other networking-related items (unless the computer has no network or internet connection, in which case these items can be disabled)



*Norton Ghost is highly recommended, as it lets you save your system in a working state and easily revert to that state should you accidentally disable anything that your computer needs.*

### To Disable System Startup Items:

1 From the Start menu, choose Run.

2 Type “msconfig” and click OK. The System Configuration Utility opens.

3 Under the General tab, choose Selective Startup.

4 Deselect Load Startup Items and click OK.

5 Click Restart to restart the computer.

6 After restarting your computer, a System Configuration message dialog is displayed. Check to see if Pro Tools performance has increased before you deselect the “don't show this message again” option. If performance has not changed, run “msconfig” and return your computer Selective Startup back to Normal Startup. Alternatively, try disabling start up items and non-essential processes individually.



## appendix b

# Configuring AMS (Mac OS X Only)

Pro Tools recognizes the ports on your MIDI interface as generic ports. With Mac OS X, you use Apple's Audio MIDI Setup (AMS) utility to identify external MIDI devices connected to your MIDI interface and configure your MIDI studio for use with Pro Tools.

### To configure your MIDI studio in AMS:

1 Launch Audio MIDI Setup (located in Applications/Utilities).

– or –

In Pro Tools, choose Setups > Edit MIDI Studio Setup.

2 Click the MIDI Devices tab. AMS scans your system for connected MIDI interfaces. If your MIDI interface is properly connected, it appears in the window with each of its ports numbered.

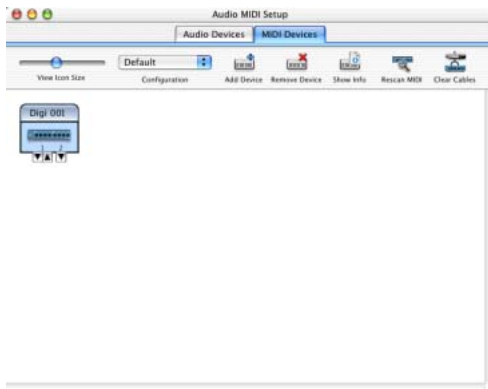

Audio MIDI Setup (MIDI Devices tab)

3 For any MIDI devices connected to the MIDI interface, click Add Device. A new external device icon with the default MIDI keyboard image will appear.

4 Drag the new device icon to a convenient location within the window.

5 Connect the MIDI device to the MIDI interface by clicking the arrow for the appropriate output port of the device and dragging a connection or “cable” to the input arrow of the corresponding port of the MIDI interface.

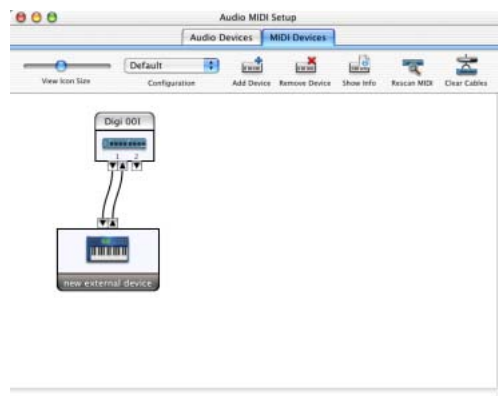

Making MIDI input and output connections

6 Click the arrow for the appropriate input port of the device and drag a cable to the output arrow of the corresponding port of the MIDI interface.

 To remove a connection, select the cable and press Delete. To delete all connections, click Clear Cables.

7 Repeat steps 3–6 for each MIDI device in your MIDI setup.

### To configure an external MIDI device:

1 Select the external device icon and click Show Info (or double-click the new device icon).



External Device Icon

2 Select a manufacturer and model for the new device from the corresponding pop-up menus. (If the Manufacturer and Model pop-up menus do not provide a name for your particular device, you can type a name.)



Naming a new MIDI device

 AMS refers to one or more files with the suffix “.middev” in the directory Root/Library/Audio/MIDI Devices for Manufacturer and Model names. Pro Tools installs two such files that contain information for many commercially available MIDI devices, “Legacy Devices.middev” and “Digidesign Devices.middev.” If the Manufacturer or Model names for any of your external MIDI devices are not available in the AMS Manufacturer and Model pop-up menus, you can add them by editing any of the current .middev files in any text editor (such as TextEdit).

**3** Click the More Properties arrow to expand the dialog, then enable the appropriate MIDI channels (1–16) for the Transmits and Receives options. (These determine which channels the device will use to send and receive MIDI.)

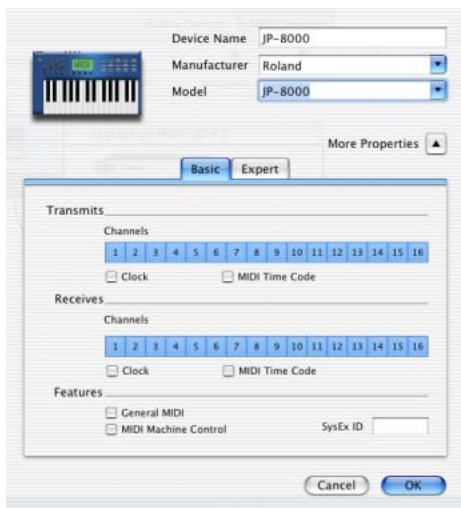

*Enabling MIDI channels*

**4** Click the device image. The window expands to show images for various MIDI devices (such as keyboards, modules, interfaces, and mixers). Select an icon for your device.



*Selecting a device icon*

 *To use your own custom icons, you can place TIFF image files in /Library/Audio/MIDI Devices/Generic/Images, and they will appear as choices in the AMS device window.*

**5** Click OK.

The device names you enter appear as MIDI input and output choices in Pro Tools.



## appendix c

# Digidesign ASIO Driver

---

## Introduction

The Digidesign ASIO Driver is a multichannel, multimedia sound driver that allows third-party audio software that supports the ASIO standard to record and play back through Digi 001 hardware.



*Check the Digidesign Web site ([www.digidesign.com](http://www.digidesign.com)) for the latest third-party drivers for Pro Tools LE hardware, as well as current known issues.*

Full-duplex recording and playback of 24- and 16-bit audio are supported at sample rates supported by the hardware and ASIO client software used.

---

## Compatibility

Digidesign can only assure compatibility and provide support for hardware and software it has tested and approved.

For a list of applications that support the ASIO Driver, refer to the latest compatibility information available on the Digidesign Web site ([www.digidesign.com/compto](http://www.digidesign.com/compto)).

---

## Installing the ASIO Driver

The ASIO Driver is installed by default when you install Pro Tools.

## Removing the ASIO Driver

If you need to remove the ASIO Driver from your computer, complete the following steps.

### To remove the ASIO Driver:

- 1 Choose Start > Control Panel.
- 2 Double-click the Add or Remove Programs icon.
- 3 From the Currently installed programs list, select your version of Pro Tools.
- 4 Click the Change/Remove button.
- 5 Modify your installation by deselecting the Digidesign ASIO Driver option only.

---

## Changing ASIO Driver Settings

Changing ASIO Driver settings is done in your third party ASIO software. Refer to the documentation that came with that software. For example, with Propellerhead Reason, click on the ASIO Control Panel button.

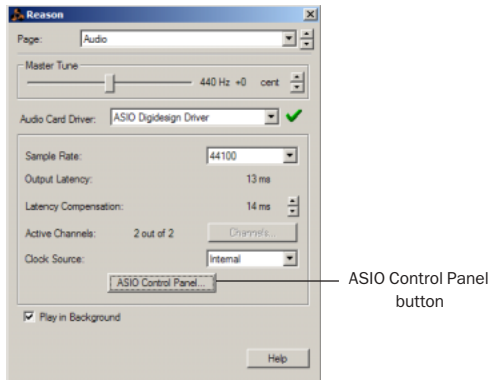

Using Propellerhead Reason

## ASIO Driver Control Panel

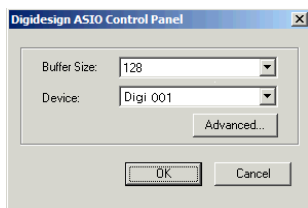

Digidesign ASIO Control Panel

The Digidesign ASIO Driver Control Panel cannot be accessed under the following circumstances:

- When Pro Tools is running.
- When playing or recording with audio software that does not support the ASIO Driver.

- When using a third-party audio software that has an option to keep the ASIO Driver “open” even when you are not playing or recording. (You must close the audio software before you can open the ASIO Driver Control Panel.)

## Buffer Size Control

When you play a file from a client audio application, the client application divides the file into small packets or *buffers*, and sends each of these to the ASIO Driver. The ASIO Driver copies the client software’s buffers to your Digidesign hardware’s own buffers in a double-buffering scheme.

The Buffer Size control in this dialog sets the size of each of the two buffers the ASIO Driver uses on Digidesign hardware. You can select from the following buffer sizes:

- 128 samples
- 256 samples
- 512 samples
- 1024 samples
- 2048 samples

◆ Small buffers reduce latency in the record monitor path. (Latency is the time delay between a signal entering the audio inputs and leaving the outputs during recording.)

◆ Larger buffers reduce audio dropouts during playback and recording.

In some third-party audio applications, performing certain tasks will interrupt the ASIO Driver and may result in clicks and pops during audio playback or recording. Choose a medium or large buffer (256, 512, or 1024) to avoid this problem.

Changing the Buffer Size for the ASIO Driver does not affect the H/W Buffer Size settings in the Pro Tools Playback Engine dialog.

## **Device**

The Device Type is always set to your installed Pro Tools hardware.

## **Advanced Button**

The Advanced button opens the Hardware Setup dialog for your Digidesign system.





## appendix d

# Configuring OMS (Mac OS 9 Only)

Pro Tools LE on Mac OS 9 requires Open Music System (OMS), which is included on the Pro Tools Installer CD.

OMS has the following capabilities:

- Keeps track of which MIDI devices you are using, how they are connected, and which patches they are using
- Enables MIDI hardware to communicate with your music applications
- Provides timing services and inter-application communication

OMS stores a description of your MIDI studio in *Studio Setup* documents, which are edited in the *OMS Setup* application. Once OMS is configured, your music applications know which MIDI devices you are using by referencing the current Studio Setup document.

The following sections provide basic instructions for configuring OMS. For more detailed information, refer to the online *OMS Guide* installed with Pro Tools.

## Configuring a New Studio Setup

Before configuring OMS, make sure the Digi 001 hardware and Pro Tools LE software have been installed, and that any other MIDI interfaces are connected according to the manufacturer's instructions and turned on.

### To configure a New Studio Setup in OMS:

- 1 Launch the OMS Setup application. If OMS has not yet been configured, you'll be prompted to configure a New Studio Setup. Click OK.
- 2 Select whether your MIDI interface is connected to the Modem or Printer port. If using a USB or PCI-based MIDI interface (including the Digi 001), leave both ports unchecked. Click Search.



Ports for OMS Driver Search

OMS searches for and displays any detected MIDI interfaces, MIDI cards, and OMS drivers. If your Digi 001 is not detected, click Troubleshoot. Once your Digi 001 is detected, you are prompted to search for MIDI instruments connected to it.

3 Click OK to search for MIDI devices connected to your Digi 001. To be detected, the device must be turned on with both of its MIDI ports connected to the MIDI ports on Digi 001.

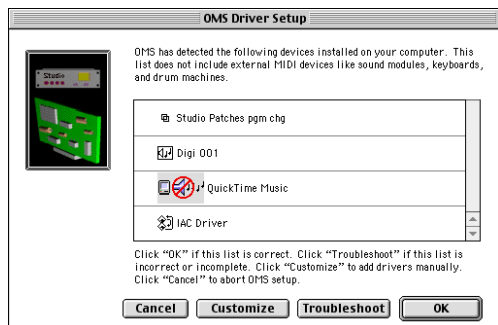

*OMS Driver Setup*

OMS searches for and displays any detected MIDI devices. Some older instruments, as well as some newer ones, may not be recognized by the OMS auto-detection routines.



*Undefined OMS device*

Devices not recognized by OMS appear with a red question mark and are named based on the interface or port to which they are connected. These devices can be defined as necessary within the OMS Setup application (see “Defining MIDI Devices in OMS” on page 84).

4 Click OK to save your Studio Setup document.

## Defining MIDI Devices in OMS

To define a MIDI device in OMS Setup:

- 1 Double-click the device’s icon in the Studio Setup window.
- 2 In the MIDI Device Info dialog, select the Manufacturer and Model for the device from the pop-up menus. If the device is not listed, leave the Model set to “other” and enter a name for the device.

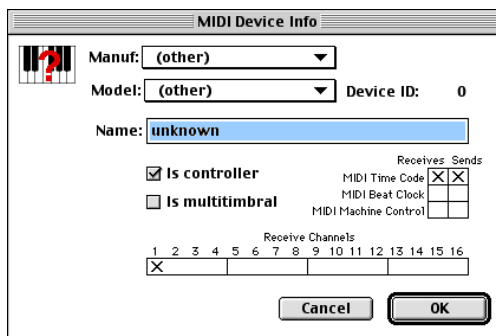

*MIDI Device Info*

3 Select the Receiving Channel for the device. If receiving multiple channels, select the option for “Is Multitimbral.”

4 If you will record from the device in Pro Tools, select the option for “Is Controller.” If the device will be a source or destination for MIDI Time Code, Beat Clock, or MIDI Machine Control, select the appropriate option.

5 Click OK.

## **Disabling SerialDMA in OMS**

Pro Tools requires that you deselect the “Use Apple SerialDMA Driver When Available” option in OMS Setup. If you do not disable this option, problems will occur with MIDI and synchronization functions within Pro Tools.

### **To disable SerialDMA in OMS:**

- 1** Double-click the OMS Setup application.
- 2** Choose Edit > Preferences.
- 3** Deselect “Use Apple SerialDMA Driver When Available,” and click OK.
- 4** Quit OMS Setup.



## appendix e

# Digidesign Control Panel (Mac OS 9 Only)

If you are running Mac OS 9 and plan to use your Digidesign hardware with Apple Sound Manager-compatible applications, you will need to install the Digidesign Control Panel.

### To install the Digidesign Control Panel:

- Run the Pro Tools LE Installer and select the Digidesign Control Panel option. (See “Installing Pro Tools LE Software” on page 20.)



Digidesign®

*Digidesign Control Panel*

### To configure the Digidesign Control Panel:

- 1 From the Apple menu, choose Control Panels > Digidesign.



*Digidesign Control Panel*

- 2 Click the Setup Hardware button in the Digidesign Control Panel.
- 3 Configure the Hardware Setup dialog.

### To use your Digidesign hardware with Apple Sound Manager:

- 1 From the Apple menu, choose Control Panels > Sound.
- 2 Select the Output tab.
- 3 Select Digidesign, and close the Sound Control Panel.
- 4 When you plan to use Pro Tools again, change the Output back to “Built-In” before you launch the Pro Tools application.



*Apple Sound Control Panel*

💡 *When using Digidesign hardware to monitor Sound Manager applications, under the Alerts tab, turn the Alert Volume control down.*



# index

## Numerics

- 26 dB pad 29
- 32K clusters 9
- 48V phantom power 30

## A

- ADAT
  - connecting 43
  - recording from Pro Tools LE 60
  - recording to Pro Tools LE 60
- ASIO driver 11, 79
- audio
  - analog 37
  - digital 39
  - importing 55, 56
  - routing 56, 66
- audio connections
  - analog 37
  - analog tape decks 42
  - digital 42
  - digital tape decks 42
  - home stereo 36
  - speakers 36
- Audio Regions List 55
- audio tracks 53
- authorization code
  - Windows 12
- authorizing Pro Tools software
  - Macintosh 21
- automation 69
  - creating 69
  - editing 70
- Auxiliary Inputs 53, 54, 62, 66

## B

- Bounce to Disk command 70

## C

- Channel Strip controls
  - Mute 66
  - Pan 66
  - Solo 66
  - Volume 66
- click 48
- Click plug-in
  - Accented parameter 47
  - Unaccented parameter 47
- Clock Source 14
- Clock Source (Macintosh) 24
- cluster size 9
- configuring Pro Tools LE for a digital source
  - Macintosh 26
  - Windows 15
- connecting
  - digital devices 42
  - footswitch 44
  - headphones 36
  - MIDI devices 44
  - to a mixdown recorder 42
  - to an ADAT 43
- CPU Usage Limit 22

## D

- DAE Playback Buffer Size (Macintosh) 23
- DAE Playback Buffer Size (Windows) 13
- defragment
  - Windows 9

- Digi 001 1
  - input levels 57
  - installing in a Macintosh 17
  - installing in a Windows PC 8
  - what's included 1

- Digi 001 I/O
  - connecting 8, 18
  - footswitch jack 31
  - headphone gain 30
  - headphone output 30
  - input gain knobs 29
  - input pad 29
  - main analog outputs 32
  - Mic/Line inputs 29
  - MIDI I/O 31
  - monitor inputs 31
  - monitor outputs 32
  - monitor volume 30
  - phantom power 30
  - power on indicator 30
  - S/PDIF I/O 31

- Digi 001 PCI card 1, 18
  - optical input 32
  - optical output 32

- digital audio
  - ADAT format 39
  - S/PDIF format 39

- digital devices
  - connecting 42

- Digital I/O format (Macintosh) 25

- Digital I/O format (Windows) 14

- digital source
  - configuring Macintosh 26
  - configuring Windows 15

- Disk Cleanup 9

- DMA 5

## **E**

- Edit mode buttons 63

- Edit modes 63
  - Grid 63
  - selecting 63
  - Shuffle 63
  - Slip 63
  - Spot 63

- Edit tools 63
  - Grabber 63
  - Pencil 63
  - Scrubber 63
  - Selector 63
  - Smart Tool 63
  - Trimmer 63
  - Zoomer 63

- Edit window 46
- editing regions 64
- external effects devices 40

## **F**

- fade files 45
- FAT32 9
- footswitch jack 31

## **G**

- gain
  - headphone 30
  - Mic/Line inputs 57
- Grabber tool 63
- Grid mode 63

## **H**

- hard drive
  - and Windows system drive 10
- hard drives
  - cluster size 9
  - maintenance 9
  - space requirements 3
  - Windows maintenance 9
- Hardware Buffer Size 61
- Hardware Buffer Size (Macintosh) 22
- hardware installation 5
- headphones
  - connecting 36
  - gain 30
  - output 30
- HFS 11
- Hibernate 6
- high-pass filter 59



## I

- I/O Setup
  - Macintosh configuration 15, 27
- importing audio 55, 56
- input gain
  - fine tuning 58
  - on Mic/Line inputs 57, 58
- input gain knobs 29
- input levels 57
- input pad 29
- inputs
  - analog 32
  - Mic/Line 29
  - monitor 31
  - S/PDIF 31

## L

- latency 60
- low latency monitoring 61

## M

- Macintosh
  - system settings 18
- MacOpener 11
- main analog outputs 32
- Master Faders 53, 54, 68
  - creating 68
- memory locations 51, 52
  - defining 51
  - recalling 51
- Mic/Line high-pass filter 59
- Mic/Line inputs 29
- MIDI 62
  - recording 61
- MIDI click 48
- MIDI connections 44
- MIDI control surface 70
- MIDI controls 47, 48
- MIDI devices, connecting 44
- MIDI I/O of Digi 001 I/O 31
- MIDI Regions List 55
- MIDI tracks 53, 54
- Mix window 46, 66
- mixdown 42
- mixing 66
- monitor inputs of Digi 001 I/O 31

- Monitor mode 30, 41
- monitor outputs of Digi 001 I/O 32
- monitor volume 30
- monitoring 62
  - latency 60
  - Low Latency Monitoring option 61
  - MIDI 62
- multi-processor 22
- Mute button 66

## N

- NTFS 9

## O

- OMS (Open Music System) 21, 83
  - configuring 83
  - defining a MIDI device 84
  - disabling SerialDMA 85
  - installing 21
- optical input 32
- optical output 32

## P

- Pan slider 66
- PCI card 8, 18
- Pencil tool 63
- phantom power 30
- playback
  - starting and stopping 50
- Playback Engine dialog 49
- playlists 65
- plug-ins 69
- power
  - Windows System Standby 6
- power on indicator of Digi 001 I/O 30

## Pro Tools

- automation 69
- editing 63
- main windows 46
- plug-ins 69
- recording audio 59
- recording MIDI 61
- saving sessions 48
- signal routing 66
- starting a session 45
- system resources and settings 49

## Pro Tools LE

- capabilities 2
- installing, Macintosh 20
- installing, Windows 10

## Q

QuickTime 10

## R

### recording

- an audio track 59
- from ADAT tracks 60
- MIDI 62
- monitoring latency 60
- to ADAT tracks 60

### regions 64

- arranging 64
- creating 64
- editing 64
- trimming 64

### returns 67

- creating 67

### rulers 46

## S

S/PDIF I/O (RCA) 31

S/PDIF Mirroring 39

Sample Rate (Macintosh) 24

Sample Rate (Windows) 14

Scrubber tool 63

Selector tool 63

sends 54, 67

- assigning 67

SerialDMA, disabling 85

sessions 45

- creating 45
- duplicating 49
- navigating 50
- saving 45, 48
- saving copies of 49

Shuffle mode 63

signal-to-noise performance 57

Slip mode 63

Smart Tool 63

Solo button 66

Spot mode 63

studio setup diagrams 34

submixing 66

System settings

- for Windows 5

system settings

- Clock Source 14
- CPU Usage Limit 22
- I/O Setup 15, 27
- Macintosh 18
  - Clock Source 24
  - DAE Playback Buffer Size 23
  - Digital I/O format 25
  - Hardware Buffer Size 22
  - Sample Rate 24
- Pro Tools 49
- Windows
  - DAE Playback Buffer Size 13
  - Digital I/O format 14
  - Sample Rate 14

## T

- Tascam DA-30 42
- tempo 47
  - setting 47
- tempo events 47
- track height
  - changing 52
- tracks
  - audio 53, 54
  - Auxiliary Inputs 53, 54, 66
  - creating 53
  - Master Faders 53, 54, 68
  - MIDI 53, 54
  - playing back 59
  - playing back MIDI 62
  - recording 59
  - recording MIDI 62
  - types 53
- Transport controls 49
- Transport window 46, 49
- Trimmer tool 63
- trimming regions 64

## V

- validating Pro Tools software
  - Macintosh 21
- Volume fader 66

## W

- Windows
  - required System settings 5
  - System Standby 6
- windows 46
  - Edit window 46
  - Mix window 46, 66
  - Transport window 46, 49
- Windows System Standby 6
- Windows XP
  - maintenance 9

## Z

- Zoom presets 52
  - recalling 52
  - storing 52
- Zoomer tool 63
- Zooming 52