

Pro Tools

Addendum

Version 5.3.3 for HD Systems on Windows

Digidesign

2001 Junipero Serra Boulevard
Daly City, CA 94014-3886 USA
tel: 650-731-6300
fax: 650-731-6399

Technical Support (USA)

tel: 650-731-6100
fax: 650-731-6384

Product Information (USA)

tel: 650-731-6102
tel: 800-333-2137

International Offices

Visit the Digidesign Web site
for contact information

Web Site

www.digidesign.com



digidesign

Copyright

This addendum is copyrighted ©2002 by Digidesign, a division of Avid Technology, Inc. (hereafter "Digidesign"), with all rights reserved. Under copyright laws, this addendum may not be duplicated in whole or in part without the written consent of Digidesign.

DIGIDESIGN, AVID and PRO TOOLS are trademarks or registered trademarks of Digidesign and/or Avid Technology, Inc. All other trademarks are the property of their respective owners.

All features and specifications subject to change without notice.

PN 934210772-00 REV A 09/02

contents

Chapter 1. Introduction	1
5.3.3 System Requirements	1
Compatibility Information	2
Upgrading to Pro Tools HD	2
Updating to Pro Tools 5.3.3	3
Chapter 2. Installing and Configuring Pro Tools HD	5
Installing Windows XP	5
Configuring Your Computer	6
Installing Pro Tools Hardware	10
Installing Pro Tools Software	16
Installing QuickTime	18
Using MIDI	18
Installing ProControl or Control 24	18
Checking Your HD System and Launching Pro Tools	19
Configuring Pro Tools	22
Chapter 3. What's New in Pro Tools 5.3.3	29
SYNC I/O	29
4% Pull Up and Pull Down	31
25P	36
Avid Unity Support	36
PRE Remote Controlled Microphone Preampfier	38
Multi-DSP 48-bit Mixer	39
Meters and QuickPunch Record Enabled Tracks	40
Calculate Overviews for Exported Files	41

Chapter 4. What's New in Pro Tools TDM 5.3.1	43
Support for Pro Tools HD Hardware	43
Support for SYNC I/O	46
Software Enhancements	46
New TDM Mixer Plug-Ins	50
Plug-In and Processing Features	50
New Avid Inter-operability Support	53
MachineControl Update	55
Voice Load Balancing and PCI Optimization	56
WAV Now BWF	56
QuickTime Playback	56
24-Bit Sessions on IDE Drives	57
Chapter 5. Corrections to the 5.3 Guides	59
Pro Tools 5.3 Reference Guide	59
Getting Started with HD Guide	63
192 Digital I/O Guide	64
192 I/O Guide	64
96 I/O Guide	65
SYNC I/O Guide	65
AVoption XL Guide	66
Expanded Systems Guide	66
ProControl Guide	67
Control 24 Guide	67
PRE Guide	68
Key Commands	68

Introduction

This addendum is a supplement to the Pro Tools TDM 5.3 guides. It documents the new and changed features in Pro Tools TDM 5.3.3 for Pro Tools|HD systems.

- ◆ If you are new to Pro Tools|HD, or are configuring a new system, begin by following the hardware and software installation instructions in Chapter 2, “Installing and Configuring Pro Tools|HD.” Additional information can be found in the *Getting Started with HD Guide*. Use this addendum to learn about new features.
- ◆ If you are upgrading an HD system to Pro Tools 5.3.3, install the upgrade (see “Updating to Pro Tools 5.3.3” on page 3) and use this addendum to learn about new and changed features.

New Features

Pro Tools TDM 5.3.3 includes the following new or enhanced features on Windows XP. Descriptions of these features begin in Chapter 3, “What’s New in Pro Tools 5.3.3.”

- SYNC I/O Features
 - Loop Sync support
 - 4% pull up pull down
 - Auto ID of SYNC I/O
 - Reduced jitter options with LTC
 - Automatic PAL/NTSC Switch
- Improved AVoption|XL support
 - Supports 25P with FilmFrame™ option
- Support for Avid Unity™ MediaNetwork 3.1 and MediaManager 3.5
- Support for PRE remote-controlled microphone preamplifier
- Multi-DSP 48-bit Mixer
- Meters on QuickPunch Record-Enabled Tracks
- Overviews stored with exported files

5.3.3 System Requirements

Pro Tools TDM 5.3.3 requires the following:

- Pro Tools|HD systems
- Digidesign-qualified, single processor computer:
 - Pentium 4 with Intel 860 or Intel 850 chipsets
 - Pentium III with VIA Apollo Pro133 or Intel 440BX chipsets
- CD-ROM or equivalent drive
- AGP display card

- Windows XP Professional Edition or Home Edition

 *If you are changing operating systems, Digidesign strongly recommends a clean install of Windows on a newly formatted drive or partition rather than upgrading the operating system.*

 *If you are upgrading your operating system, be sure to deauthorize any key disk authorized plug-ins prior to upgrading your operating system so that you don't lose your authorizations during the upgrade.*

- At least 256 MB RAM
- Additional RAM is required for:
 - High edit density sessions, extensive use of plug-ins, and addition of options such as MachineControl, DigiTranslator, and AVoption|XL (512 MB recommended)
 - Sessions with more than 64 tracks at 44.1/48 kHz, 32 tracks at 88.2/96 kHz, and 12 tracks at 176.4/192 kHz (384 MB minimum, 512 MB recommended)
- Color monitor required, minimum resolution of 1024 x 768

Compatibility Information

Pro Tools 5.3.3 supports Pro Tools|HD on Windows XP Professional or Home Edition.

Pro Tools 5.3.3 provides support for AVoption|XL, and Avid Unity MediaNet 3.0 and Avid Unity MediaNetwork 3.1 only on Windows XP Professional Edition.

Digidesign can only assure compatibility and provide support for devices it has tested and approved. For the latest compatibility information, refer to the Digidesign Web site at:

www.digidesign.com

Upgrading to Pro Tools|HD

If you are upgrading from a Pro Tools|24 MIX or Pro Tools|24 system to Pro Tools|HD, you will need to complete the following steps.

To upgrade to Pro Tools|HD:

1 Deauthorize any key disk authorized plug-ins installed on your system.

 *You will need to update or upgrade your Digidesign and third-party plug-ins to be compatible with Pro Tools|HD.*

2 Use the Add/Remove Programs control panel to Remove your current installation of Pro Tools.

3 Use the Add/Remove Programs control panel to Remove PACE System Files.

4 Shut down and turn off your computer.

5 Remove the currently installed Digidesign hardware.

6 Upgrade your operating system to Windows XP Home edition or Windows XP Professional edition if necessary.



If you are changing operating systems, Digidesign strongly recommends a clean install of Windows on a newly formatted drive or partition rather than upgrading the operating system.

7 Install Pro Tools|HD software and hardware according to the installation instructions in Chapter 2, “Installing and Configuring Pro Tools|HD.”

Updating to Pro Tools 5.3.3

If you already are a registered owner of Pro Tools 5.3.1 and already have Pro Tools|HD installed on your system, Pro Tools 5.3.3 is a free update. The installer for Pro Tools 5.3.3 is available for download from:

www.digidesign.com

To upgrade from Pro Tools|HD 5.3.1 to Pro Tools|HD 5.3.3:

- 1** Choose Control Panel from the Start menu.
- 2** Double-click on Add or Remove Programs.
- 3** Select Digidesign Pro Tools® 5.3.1.
- 4** Click Change/Remove. The InstallShield Wizard launches.
- 5** Select Remove.
- 6** Click Next.
- 7** Click OK to confirm the uninstall.
- 8** When prompted, click Finish.
- 9** Launch the Setup.exe for Pro Tools 5.3.3.
- 10** Click Next.

11 Click OK to accept the License Agreement.

12 Select the hard drive on which to install Pro Tools from the Install pop-up menu. For maximum reliability, install Pro Tools on your startup drive.

13 Click Next.

14 Choose the desired install option (Typical or Custom).

15 Click Next.

16 Select a “work environment” and click Next.

17 Select whether to install the Surround Mixer plug-in, and then click Next.

18 When installation is complete, click Finish to restart your computer.



For complete instructions on installing Pro Tools, see Chapter 2, “Installing and Configuring Pro Tools|HD.”

Validate Pro Tools Software

When launching Pro Tools the first time, you are prompted to enter an authorization code to validate your software.

To validate Pro Tools software:

- 1 Double-click the Pro Tools application in the Pro Tools folder inside the Digidesign folder.
- 2 Enter the authorization code in the dialog when prompted, making sure to observe any spaces, then click Validate.

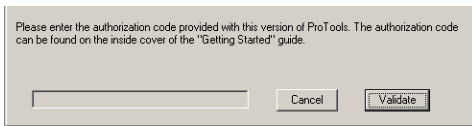

Authorization code validation for Pro Tools



The authorization code is located on the inside cover of your Getting Started Guide.

chapter 2

Installing and Configuring Pro Tools|HD

The complete Pro Tools installation process includes:

- Installing Windows XP
- Configuring your computer
- Installing Pro Tools hardware
- Installing Pro Tools software
- Checking your TDM System and Launching Pro Tools
- Configuring Pro Tools

 *If you are upgrading to Pro Tools|HD from Pro Tools|24 MIX or Pro Tools|24, see “Upgrading to Pro Tools|HD” on page 2.*

Installing Windows XP

If you do not already have Windows XP installed on your computer, you will need to install Windows XP Home edition or Windows XP Professional edition. Pro Tools requires an activated version of Windows XP.

 *If you are changing operating systems, Digidesign strongly recommends a clean install of Windows on a newly formatted drive or partition rather than upgrading the operating system.*

 *If you are upgrading your operating system, be sure to deauthorize any key disk authorized plug-ins prior to upgrading your operating system so that you don't lose your authorizations during the upgrade.*

Configuring Your Computer

To ensure optimum performance with Pro Tools, configure your computer before installing Pro Tools software.

⚠ *Before you make any changes to your computer's system settings, make a backup copy of your Registry (where many of these essential settings are stored). By doing so, you will be able to restore your system's original settings in case of trouble. See your Windows XP documentation for details.*

If your computer does not provide the BIOS configuration options included in this section, or if you do not feel comfortable changing system parameters, consult with a Windows system administrator, or your computer dealer or manufacturer for assistance.

Configuring your computer consists of:

- Configuring your BIOS (if necessary)
- Configuring your SCSI BIOS (if necessary)
- Installing the SCSI drivers (if necessary)
- Setting Display Effects and Application Response
- Disabling Virus-Protection Software
- Disabling the Driver Signing Option

Configuring Your BIOS

BIOS (Basic Input/Output System) parameters vary depending on the make and model of the computer. Refer to the documentation that came with your computer for more details.

Different BIOS manufacturers often use different names to describe the same system function. Some manufacturers do not provide a particular configuration option at all. Consequently, the names and options that appear in your computer's BIOS may differ from those described in this addendum.

 *The following BIOS settings are not applicable to the Compaq Evo W8000 and the IBM Intellistation M Pro 6850.*

To modify your computer's BIOS:

- 1 Start or restart your computer.
- 2 During power up, enter BIOS Setup by pressing the appropriate key on your computer keyboard. On most computers, this is F1, F2, or the Delete key. Refer to the documentation that came with your computer.
- 3 Disable PCI Parity, if present.
- 4 If using SCSI drives or devices, and your computer is equipped with built-in SCSI hardware, enable SCSI support. SCSI support parameters are typically found on the Devices & I/O Options page of the BIOS setup utility. If you do not have built-in SCSI hardware and are using a SCSI host adapter card instead, you do not need to enable SCSI support.
- 5 Disable Power Management, if present.
- 6 Enable PCI Dynamic Bursting, if present.
- 7 Save settings.
- 8 Exit BIOS setup and restart your computer.

Configuring Your SCSI BIOS

If you are using SCSI drives or devices, you must modify the settings of your built-in SCSI hardware or SCSI adapter card. This allows SCSI hard drives to work properly with Pro Tools. This procedure varies on different computers. Consult the documentation that came with your computer.

To modify your computer's SCSI BIOS:

- 1 Start or restart your computer.
- 2 During power up, when the text message regarding the SCSI BIOS appears, press the key combination listed on the screen to enter the SCSI BIOS. The SCSI BIOS setup utility appears.
- 3 Consult your SCSI host bus adapter's documentation to set the following parameters:
 - For each SCSI ID and SCSI channel connected to your audio drives, set the Maximum Sync Transfer Rate parameter to 20 MB/sec for the ATTO EPCI-DC or to Ultra 160 for Ultra 160 cards.
 - If you are using an ATTO HBA, change the PCI Burst Size to 128 Bytes and the Burst Length Selection Timeout to 16 ms (UL3D only).
 - If you are using an Adaptec HBA, enable the Host Adapter BIOS option.
- 4 Save settings.
- 5 Exit SCSI BIOS setup and restart your computer.

If you are using the ATTO SCSI HBA card, you may need to flash its SCSI BIOS. When booting your computer, you will see what version of the ATTO SCSI BIOS is installed on the SCSI card. If it is not version 1.6.6 or higher, you will need to flash the SCSI BIOS with 1.6.6 or higher ATTO SCSI BIOS (flash.bat).

Flashing the BIOS on the SCSI card using the ATTO SCSI BIOS:

- 1 Insert a High Density PC formatted floppy disk.
- 2 Copy the DOS folder from the ATTO folder on the Pro Tools Installer CD-ROM to the floppy disk.
- 3 Shut Down your computer.
- 4 Disconnect any hard drives connected to the SCSI card.
- 5 Boot your computer with the floppy disk in the floppy drive.
- 6 When prompted, press Ctrl+Z.
- 7 Press Enter.
- 8 Select Adapter Menu.
- 9 Select Update Flash BIOS.
- 10 Press Enter twice.

The SCSI BIOS will be updated. This may take a few minutes.

 *Do not interrupt this process or your system may be severely damaged.*

- 11 Select Configure Adapter Channels.
- 12 Set Host Adapter BIOS to Scan Only.
- 13 Press the Esc key twice.
- 14 Select Save Parameters and Exit, and press Enter.

Installing SCSI Drivers

For Pro Tools to run at maximum efficiency with SCSI Host Bus Adapters and SCSI drives, install a Digidesign approved SCSI driver (ATTO or Adaptec, depending on the card you are using).



Check Digidesign's Compatibility Documents for a list of Digidesign approved computers and supported SCSI driver versions:

www.digidesign.com

Installing the Adaptec Windows Device Driver

If you need to install the Adaptec driver, consult the manufacturer's documentation.

The full name of the Adaptec driver for the IBM M Pro or Compaq Evo W8000 is:

- Adaptec AHA290/291/294x/394x/4944/AIC78xx

Installing the ATTO Windows Device Driver

To install the ATTO Windows device driver:

- 1 Start up your computer. Note the version of the ATTO SCSI BIOS when booting. If it is version 1.6.6, proceed to the next step. If it is not version 1.6.6, you will need to flash the ATTO SCSI BIOS (see "Configuring Your SCSI BIOS" on page 7).
- 2 Insert the Pro Tools Installer CD-ROM.
- 3 From the Start Menu, choose Control Panel.
- 4 Double-click on System. The System dialog opens.
- 5 Select the Hardware tab.
- 6 Click Device Manager.
- 7 Select SCSI and RAID controllers.

- 8 Double-click the LSI PCI SCSI Adapter.
- 9 Select the Driver tab.
- 10 Click Update Driver.
- 11 Select "Install from specified location."
- 12 Select "Don't search, I'll choose the driver to install."
- 13 Click Next.
- 14 Click Have Disk.
- 15 Click Browse and navigate to the ATTO folder on the Pro Tools Installer CD-ROM.
- 16 Select EXPRESS.INF and click Open.
- 17 Click OK.
- 18 Click Next.
- 19 Click Finish.
- 20 Click Close.
- 21 If you have a dual-channel SCSI card, repeat steps 12–23 for the second channel.
- 22 Click OK.

The full name of the ATTO driver is:

- ATTO ExpressPCI

Setting Display Effects and Application Response

The next step in configuring your computer is setting your system's Display Effects. These settings will provide better font display and improve graphics performance when dragging windows in Pro Tools.

To configure Display Effects:

- 1 From the Start Menu, choose Control Panel.
- 2 Double-click on Display. The Display Properties dialog opens.

- 3 Click the Appearance tab.
- 4 Click Effects. The Effects dialog opens.
- 5 Select “Use the following method to smooth edges of screen fonts.”
- 6 Select “Clear Type” from the pop-up menu.
- 7 If “Show window contents while dragging” is selected, disable it.
- 8 Click OK to save your settings and close the Effects dialog.
- 9 Click Apply.
- 10 Click OK to close the Display Properties dialog.

Once you have configured Display Effects, configure the Application Response parameter.

To configure Application Response:

- 1 From the Start Menu, choose Control Panel.
- 2 Double-click on System. The System Properties dialog opens.
- 3 Click the Advanced tab.
- 4 Under Performance, click Settings. The Performance Options dialog opens.
- 5 Click the Advanced tab.
- 6 Under Processing Scheduling, select Background Services.
- 7 Click Apply.
- 8 Click OK to close the Performance Options dialog.
- 9 Click OK to close the System Properties dialog.

Disabling Virus-Protection Software

If you are using virus-protection software, turn it off or remove it and restart your computer. Avoid running virus-protection software while using Pro Tools since it adversely affects system performance.

Disabling Driver Signing Warning

Before you begin to physically install your Pro Tools cards, temporarily disable the Driver Signing warning option. This expedites and automates much of the installation process. If you do not temporarily disable the warning, warning messages (that you are installing an unsigned driver) appear after each DSP chip is detected during the Pro Tools installation process.

To disable the warning option:

- 1 Turn on your computer.
- 2 Open the Control Panel.
- 3 Launch the System control panel.
- 4 Select the Hardware tab in the System control panel.
- 5 Click the Driver Signing button.
- 6 Select “Ignore—Install the software anyway and don’t ask for my approval.”
- 7 Click OK twice.
- 8 Shut down and turn off your computer.
- 9 Proceed with physically installing your Pro Tools hardware.

Installing Pro Tools Hardware

Pro Tools|HD Hardware

Pro Tools|HD hardware comes in three configurations:

Pro Tools|HD 1 Includes a single HD Core card.

Pro Tools|HD 2 Includes an HD Core card, an HD Process card, and a TDM FlexCable for connecting the HD Core to the HD Process card.

Pro Tools|HD 3 Includes an HD Core card, two HD Process cards, and two TDM FlexCables (one for connecting the HD Core to the first HD Process card, and the other for connecting the first HD Process card to the other HD Process card).

 *Additional HD Process cards may be added to expand your Pro Tools system. Up to seven HD cards are supported in a single Pro Tools|HD system.*

 *If you are using an Expansion Chassis to add additional cards to your system, refer to the Expanded Systems Guide included with your Pro Tools system.*

The HD Core Card

The HD Core card provides up to 96 tracks of direct-to-disk recording and playback, and 32 channels of I/O to your Pro Tools HD-series system, as well as DSP power for processing and mixing. The HD Core card supports up to 24-bit and up to 192 kHz sessions.

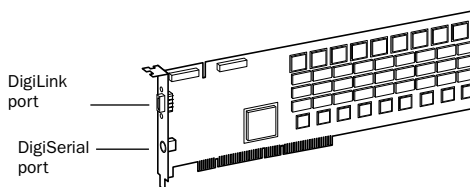

HD Core card

This card includes a single DigiLink port for connecting up to 32 channels of I/O.

The DigiSerial port is for connecting a Digidesign SYNC I/O. This connector is an 8-pin mini-DIN.

 *The DigiSerial port on HD Core cards does not support MachineControl connections. Use the Digidesign SYNC I/O for Pro Tools MachineControl 9-pin. A COM port (not a DigiSerial port) is required for MC Remote mode (only).*

The HD Process Card

The HD Process card provides DSP power for mixing, processing, and DSP software such as the DigiRack plug-ins included with Pro Tools. It also provides a DigiLink port for connecting up to 32 channels of I/O.

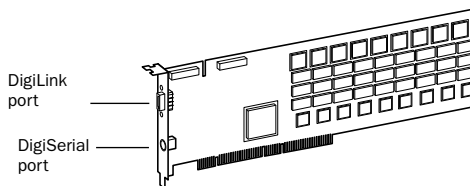

HD Process card

The DigiSerial port on an HD Process card does not offer any user functionality at this time.

The TDM FlexCable

The TDM FlexCable is used to connect a pair of cards in your Pro Tools system so they can share data along the TDM bus. Additional FlexCables are required to connect additional cards. One FlexCable comes with each HD Process card.

⚠ *The TDM FlexCable is actually a flexible printed circuit board with delicate traces. Do not overbend the cable, twist it, or otherwise pinch it. Doing so may cause unpredictable behavior in Pro Tools as well as harm to your system.*

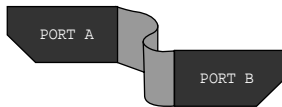

TDM FlexCable

Installing the Pro Tools|HD Cards

This section shows how to install Pro Tools HD cards into a Windows CPU. If you're installing cards into an expansion chassis, see the *Expanded Systems Guide*.

To install the Pro Tools cards:

- 1 Turn off your computer and any peripherals. Make sure the equipment is properly grounded.
- 2 Disconnect all cables attached to the CPU (such as hard drives, monitor(s), USB and firewire connections) except for power.

- 3 Open the computer case.

⚠ *Before handling any card, discharge any static electricity that may be on your clothes or body by touching a grounded metal surface, such as the power supply case inside your computer.*

- 4 Remove the metal access port cover behind the PCI slot you want to use by removing the screw and sliding the cover out from the access port. Keep the screws in a safe place.

- 5 Install the HD Core card in the first PCI slot (64-bit, if available).

- 6 Install the first HD Process card (if any) in the second PCI slot (64-bit, if available).

- 7 Install any remaining HD Process cards in the remaining consecutive PCI slots (64- or 32-bit).

- 8 If installing a SCSI HBA card, install it in the highest numbered remaining slot.

- 9 If installing other cards, verify that your cards are installed in the following order, starting with the lowest numeric slot.

💡 *The guidelines below may include optional cards not present in your system.*

For each Pro Tools|HD system, your cards should be installed in the following order:

- HD Core card (64-bit slot)
- HD Process card (64-bit slot)
- Additional HD Process cards (64- or 32-bit slots)
- SCSI host bus adapter (HBA)
- Display card for your computer monitor

10 If installing an HD Core system (and not a Pro Tools|HD 2 or HD 3 system), complete the following:

- Secure the card in place with the slot access port screw you removed earlier.
- Close the computer case.
- Skip the following steps and continue with “Connecting Audio Interfaces” on page 13.

11 If installing a Pro Tools|HD 2, HD 3, or an Expanded HD 1 system, connect the HD cards with TDM FlexCables (see “Connecting Multiple Cards with the TDM FlexCable” on page 12).

⚠ *The IBM Intellistation M Pro 6850 may not boot after updating the BIOS or changing the order of Pro Tools cards. Should this problem occur, remove all plug and play cards and you will be able to boot Windows, then shut down and re-install the cards according to the installation instructions described in “Installing the Pro Tool|HD Cards” on page 11. You should now be able to boot Windows.*

Connecting Multiple Cards with the TDM FlexCable

Each HD card has two ports along the top of the card, labelled Port A and Port B.

When installing multiple HD cards, data communication across HD cards is achieved by using a TDM FlexCable to connect Port B of the lead card to Port A of the next card. The FlexCable has two connectors, also labeled Port A and Port B, to ensure proper connection.

To connect HD cards with the TDM FlexCable:

- 1** Make sure you have secured cards with the slot access port screws you removed earlier.
- 2** The FlexCable needs to be shaped before installing it on your HD cards. To do this, grasp it with both hands, then move the Port B portion of the cable straight towards you and inwards, as shown below. Do not bend the cable more than you need to, as you may damage the traces in the cable.

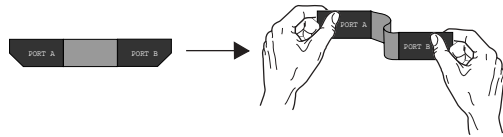

Preparing TDM FlexCable for installation

- 3** Slide the FlexCable into the notch of the *first* card, so that the Port B connector of the FlexCable can be aligned with Port B of the lead card; and the Port A connector of the FlexCable can be aligned with Port A of the second card (as shown in the following diagram).

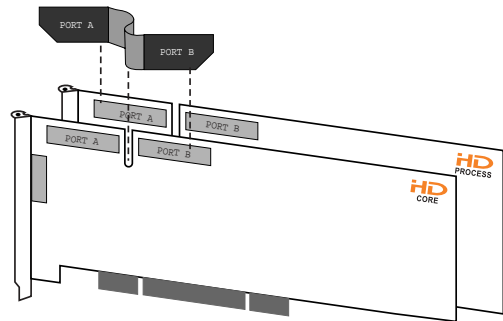

Inserting TDM FlexCable

4 Connect the Port A connector of the FlexCable to Port A on second card. Push down gently but firmly until the cable is fully connected to the card. Next, attach the other end of the FlexCable (labeled Port B) to Port B on the lead card.

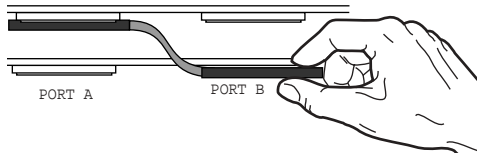

Top view of two HD cards connected with TDM FlexCable

5 Verify the connection, as shown below.

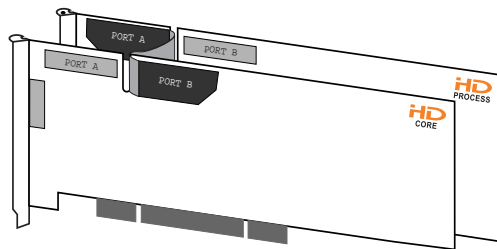

Side view of two HD cards connected with TDM FlexCable

6 For systems with more than two cards, each additional card must be connected to its preceding card. Use FlexCables to connect cards together, as described above, until all cards are connected. Each subsequent HD Process card will include a FlexCable.

Connecting Multiple Cards with the Female-to-Female TDM FlexCable

Some computers have a gap between PCI slots that exceeds the length of the TDM FlexCable. For such computers (for example, the IBM IntelliStation E Pro 6846), you will need a special adapter cable—a female-to-female TDM FlexCable used in conjunction with two regular TDM FlexCable—to connect consecutive HD Process cards across the gap. To obtain the Female-to-Female TDM FlexCable, please contact Digidesign's Technical Support.

Connecting Audio Interfaces

Each Pro Tools|HD audio interface supplies up to 16 channels of input and output to your system.

Pro Tools|HD supports up to a maximum of eight 192 I/Os, 192 Digital I/Os, or 96 I/Os.

Each HD card supports up to 32 channels; to get a full 32 channels of I/O from one card, you can connect, or daisy chain, a second 16-channel HD I/O to the first HD I/O that is connected directly to the HD card.

For examples of connecting multiple HD I/Os, see Figure 1 on page 14 and Figure 2 on page 14.

⚠ *HD audio interfaces need room at their sides to maintain proper air flow for cooling. It is important to leave room for air intake and ventilation on the sides of the unit. Do not block the sides of the unit or disconnect the internal fan. If the units are racked up in a case, remove all lids or doors before operating the system. Failure to do so can result in the units overheating very quickly, which can permanently damage sensitive components.*

Previous generations of audio interfaces can also be connected to the 192 I/O, 192 Digital I/O, or 96 I/O. These include: 888|24 I/O, 882|20 I/O, 1622 I/O, 24-bit ADAT Bridge I/O, and the original ADAT Bridge I/O. The original 888 I/O and 882 I/O interfaces are not supported with Pro Tools|HD.

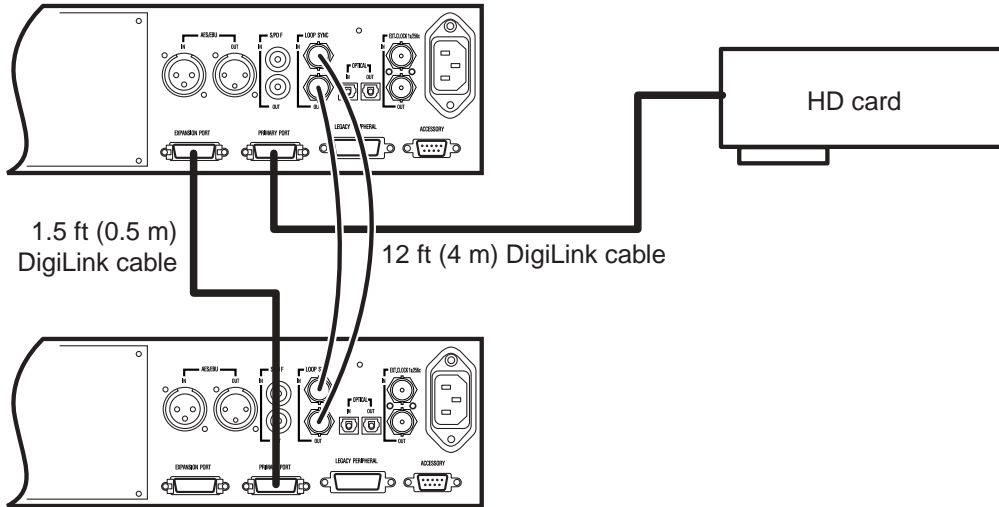

Figure 1. Two 96 I/Os, 32-channel

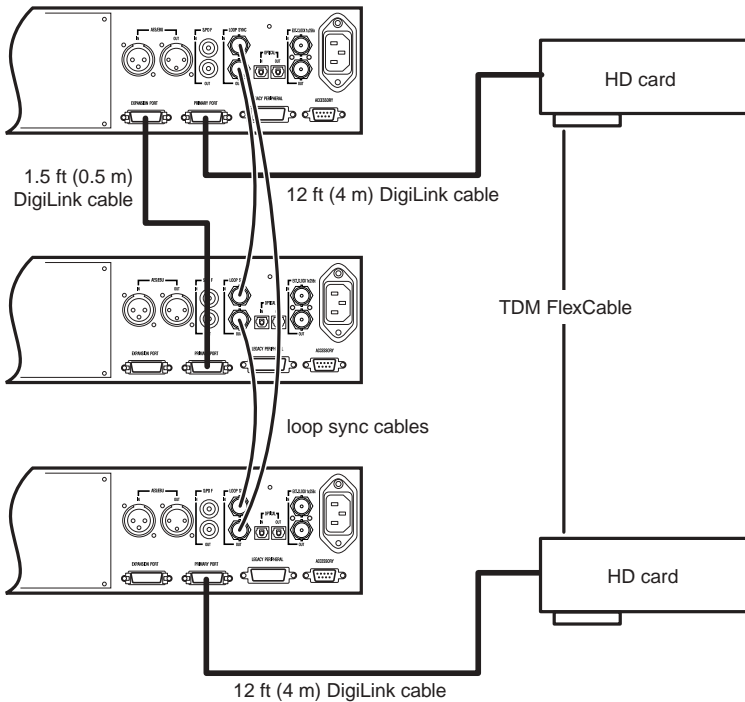

Figure 2. Three 96 I/Os, 48-channel

To connect the HD audio interfaces:

1 If using a single 192 I/O, 192 Digital I/O, or 96 I/O, connect it to the HD Core card with the provided DigiLink cable that came in the HD Core packaging. You must attach at least one 192 I/O, 192 Digital I/O, or 96 I/O to your system in order for Pro Tools to boot.

▲ *If you have at least one 192 I/O or 192 Digital I/O in your system configuration, it must be connected to the HD Core card as the “primary” interface.*

2 Connect additional HD audio interfaces to subsequent Digidesign audio cards or daisy chain your I/Os (by connecting a secondary I/O to the primary I/O).

If you are connecting both 192 I/O (or 192 Digital I/O) and 96 I/O audio interfaces to your system, connect the 192 I/O (or 192 Digital I/O) to your HD Core card, followed by any additional 192 I/O (or 192 Digital I/O) interfaces connected to the next highest-priority cards. Then connect the 96 I/O interfaces to subsequent cards.

You can also connect a single HD I/O to each HD card in your system using the provided DigiLink cables. There is no advantage to this configuration over daisy chaining I/Os.

3 If using two or more HD audio interfaces, connect the Loop Sync Out of each interface to the Loop Sync In of the next interface with the BNC cables included in your HD I/O packaging. Then, connect the Loop Sync Out of the last interface to the Loop Sync In of the primary interface.

4 If connecting a Digidesign Legacy audio interface (such as an 888|24 I/O, 882|20 I/O, 1622 I/O, or Digidesign ADAT Bridge I/O), continue with “Connecting an Additional 16 Channels of Audio to Legacy I/Os” on page 15.

Connecting an Additional 16 Channels of Audio to Legacy I/Os

Each 192 I/O, 192 Digital I/O, and 96 I/O can support 16 channels of audio to and from Digidesign Legacy peripherals. These include: 888|24 I/O, 882|20 I/O, 1622 I/O, 24-bit ADAT Bridge I/O, and the original ADAT Bridge I/O. The original 888 I/O and 882 I/O interfaces are not supported with Pro Tools|HD.

To connect Digidesign Legacy I/Os:

1 Connect the “MIX card” end of the peripheral cable that came with your Legacy I/O (60-pin side) to the Legacy Port on the primary HD audio interface. Connect the other end to the Computer Port on the Legacy I/O.

2 Connect additional Legacy I/Os, if any, in the same manner, to HD audio interfaces connected directly to HD Process cards.

– or –

If using a Y cable (16-channel peripheral cable adapter), connect this to the Legacy port first, then connect the audio interface peripheral cables to Port A and Port B of the Y cable.

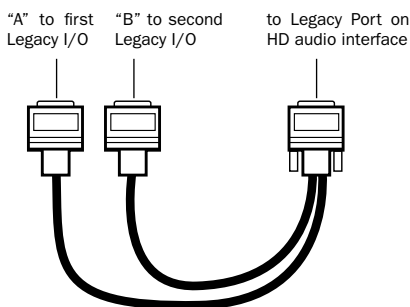



Optional 16-channel peripheral cable adapter

3 In order to properly clock the Legacy device, you will need to connect the Ext. Clock output port on the HD I/O to the Slave Clock IN on the Legacy peripheral. The Legacy peripheral will switch to Slave mode once the proper clock is outputting from the HD I/O. Always use the Ext. Clock Out port of the same I/O to which the Legacy peripheral is attached.

If using multiple MIX-series audio interfaces, connect the Slave Clock Out of the first interface to the Slave Clock In of the second interface with the provided BNC cable. (Both MIX-series audio interfaces must be connected to the Legacy port of the HD I/O using a 16-channel peripheral cable adapter.)

You cannot slave more than two MIX-series audio interfaces to a single HD-series audio interface. If you have a third MIX-series audio interface, it would get its 256x clock from the HD I/O to which it is attached.

 *In order to ensure the proper functioning of legacy audio interfaces (such as an 888|24 I/O or 882|20 I/O), it is recommend that you launch Pro Tools and declare the legacy audio interfaces in the Hardware Setup dialog prior to powering on your legacy audio interfaces. Then quit Pro Tools, shut down your computer, power on your audio interfaces and turn on your computer.*

 *Before you turn on and configure your Legacy I/O, turn down the volume of output devices. Very loud digital noise may be emitted before the Legacy I/O is initialized.*

Installing Pro Tools Software

To install Pro Tools software:

- 1 Turn on your computer.
- 2 Start up Windows, logging in with Administrator privileges. If you do not have Administrator privileges or do not know how to set them up, see your Windows User's Guide.
- 3 Wait for the Found New Hardware Wizard dialog to appear and *leave it open*.
- 4 Place the Pro Tools Installer CD-ROM for Windows in your CD-ROM drive. Locate (in the Pro Tools Installer folder) and double-click the Setup icon.
- 5 Click Next.
- 6 Click OK to accept the License Agreement.
- 7 Select the hard drive on which to install Pro Tools from the Install pop-up menu. For maximum reliability, install Pro Tools on your startup drive.
- 8 Click Next.
- 9 Digidesign recommends choosing the Typical Install option. However, if you choose Custom Install, the next window will ask you to choose the options you want to install. To install any of these items, you must select them from the following list:
 - Program Files** The Pro Tools executable and all support DLLs.
 - Plug-Ins** The DigiRack plug-ins. These files are required by Pro Tools.
 - Controllers** The Pro Tools Control Surface Personalities.
 - Documentation** Pro Tools documentation and release notes.

System Files Digidesign System Files. These files are required by Pro Tools.

Digidesign Hardware Drivers The Windows drivers for Digidesign Hardware.

Pro Tools Utilities The DigiTestHD utility and calibration test tones.

Codecs The Pro Tools Audio Codecs: MP3, RealAudio, and Windows Media.

Localized Documentation Pro Tools documentation and release notes in French, German, Italian, and Spanish.

Answerbase The stand-alone Pro Tools multilingual information databases. Note that these files require approximately 37 MB of disk space.

DigiTranslator A Pro Tools option that enables the exchange of audio and video files, and sequences between OMFI-compatible applications and Pro Tools.

 For more information on DigiTranslator, see the DigiTranslator Guide.

 A demo version of MacOpener is included on the Pro Tools Installer CD-ROM, and requires a separate installation process. MacOpener is not required for Pro Tools, it is only required if you need to use HFS or HFS+ formatted hard drives.

10 Click Next.

11 Select a “work environment.” This is an initial set of Pro Tools Preferences. These Preference “sets” have been pre-configured to include some of the more popular settings for post production, audio, and audio with MIDI. Click Next.

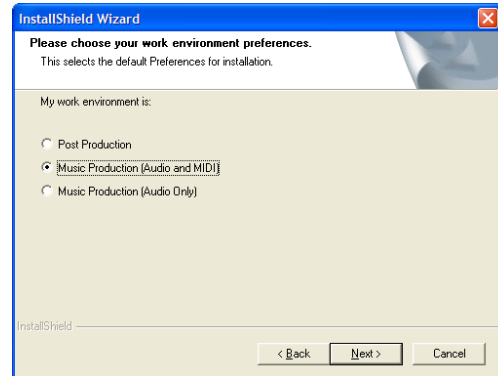

Selecting a Pro Tools Work Environment

 Preference settings can be customized at any time in Pro Tools. See the Pro Tools Reference Guide for more information about Preferences.

12 Select whether to install the Surround Mixer plug-in. This plug-in is required for mixing, mastering, and monitoring in surround. For Surround systems, select Yes – Monitoring Pro Tools Film Format if your monitoring is configured for Film Format, or select Yes – Monitoring in Pro-Control (DTS Format) if using a ProControl dedicated controller (for surround monitoring). Select No – Stereo mixing only, if your monitoring is configured for Stereo. After making a selection, click Next.

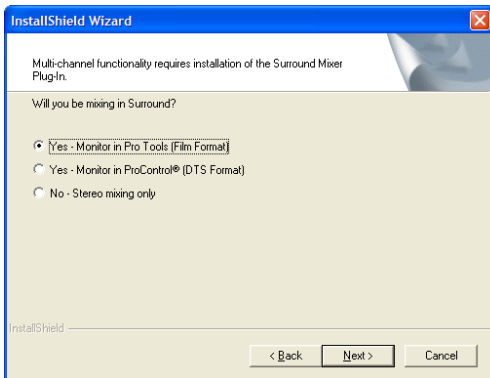

Selecting a Pro Tools Surround Mixer

13 Wait for the installer to finish installing all software components, drivers, and PACE System files before proceeding to the next step.

14 If QuickTime is not already installed, you will be prompted to install the “Recommended” QuickTime installer option now (see “Installing QuickTime” on page 18). Follow the on-screen instructions to complete the QuickTime installation process.

15 When installation is complete, click Finish to restart your computer.

If you do not follow the steps above or if you cancel any of the steps, your computer may not recognize your Pro Tools cards and you may receive the error message, “Cannot Create DAE Deck.” To resolve this error message, see “Cannot Create DAE Deck Or Error Number 4” on page 21.

Installing QuickTime

QuickTime 5.0.2 or later is recommended for Pro Tools. Install the latest version of QuickTime for Windows (available from www.apple.com). Be sure to install the “Recommended” install of QuickTime or Pro Tools will not handle QuickTime video correctly.

Using MIDI

Pro Tools in Windows uses your Multimedia Setup to configure MIDI devices and their properties. Refer to your device’s installation and usage documentation to properly configure the device.

Installing ProControl or Control|24

To install Digidesign Ethernet support for ProControl or Control|24:

- 1** On the desktop, right-click the My Network Places icon, and then choose Properties.
- 2** Right-click the relevant Local Area Connection icon, and then choose Properties.
- 3** Click Install, select Protocol and click the Add button.
- 4** Click Have Disk.

5 Select the DigiNet.inf file in either the Procontrol or Control|24 directory (on your Pro Tools Installer CD-ROM in Additional Files\Controllers\Controlllers\), and click OK.

The Installer installs the DigiNet.inf files in the Procontrol or Control|24 directory in Digidesign\DAE\Controlllers\.

6 Click Close when finished.

Checking Your HD System and Launching Pro Tools

Before you launch Pro Tools, run the DigiTestHD diagnostics application located in the Digidesign Utilities folder (see “Running DigiTestHD” on page 19). DigiTestHD finds your cards and confirms that they are correctly installed and working.

When DigiTestHD has completed and you have rebooted your computer, launch Pro Tools for the first time.

 *DigiTestHD is only compatible with Pro Tools|HD. Earlier versions of DigiTest are not compatible with Pro Tools|HD.*

Starting Up Your System

Whenever you start your system, you must turn on all of your system components in a specific order.

Start your Pro Tools System in this order:

- 1 Make sure all your equipment (including your CPU) is off.
- 2 For TDM systems with an expansion chassis, turn on the expansion chassis.

3 Turn on external hard drives, if any. Wait approximately ten seconds for them to spin up to speed.

4 Turn on any MIDI interfaces and devices, or synchronization peripherals.

5 Lower the volume of your monitoring system (such as your mixer and speakers), then turn on your Pro Tools audio interfaces (such as 192 I/O). On power up, the status LEDs will flash. Wait at least fifteen seconds for the audio interface to initialize, and the status LEDs to stop blinking and stay lit.

If you launch Pro Tools without turning on your audio interfaces, you will be prompted to turn them on. Allow fifteen seconds for audio interfaces to power-up and the status LEDs to stop blinking and stay lit, before clicking OK.

6 Turn on your computer.

7 Raise the volume of your monitoring system to an appropriate level.

Running DigiTestHD

Run the DigiTestHD diagnostics application to identify TDM cards and verify that they are correctly installed and working.

 *DigiTestHD is included on the Pro Tools Installer CD and installed with Pro Tools. DigiTestHD resides in the Digidesign Utilities folder located in your hard drive, in Digidesign/Pro Tools/Pro Tools Utilities.*

 *Before you run DigiTestHD, lower the volume of all output devices. Very loud digital noise may be emitted during the test.*

To run DigiTestHD:

- 1 Turn off Pro Tools.
- 2 Go to Start > Programs > Digidesign > Pro Tools > DigiTestHD.
- 3 Test cards.
 - To test only one Digidesign card in your system, click the button that corresponds to this card.
 - To test all Digidesign cards at once, press the “Test All Cards” button.
- 4 When prompted, recycle power on all Pro Tools peripherals. Press Continue.
- 5 Check the “Test I/O Box.”



LEDs on your digital interfaces may light up during this test. This is normal. Continue to test.

- 6 Exit DigiTestHD by clicking on the “close” box on the top right hand corner of the application window.
- 7 Reboot your computer.

Errors and Undetected Cards

Complete the steps below if:

- There is a problem with a component in your system and an error message has been displayed to the right of the corresponding card’s button in DigiTestHD.
 - or –
- A supported card is installed but not automatically detected during DigiTestHD.

If a supported card is installed and is not automatically detected:

- 1 Close DigiTestHD.
- 2 Power down your system.
- 3 Reinstall the cards (see “Installing the Pro Tool|HD Cards” on page 11).
- 4 Check the card seating.
- 5 Check the TDM FlexCable connection.
- 6 Power up.
- 7 Begin DigiTestHD again.

For descriptions of all error codes, refer to Appendix B, “DigiTest Error Codes” in the *Getting Started with HD Guide*. For test details, click the Info button to the right of the reported error, then click Failures in the pop-up window and change Failures to Detailed.

If a card continues to fail DigiTestHD, contact Digidesign Technical Support:
tel: 650-731-6100

Launching Pro Tools the First Time

Validate Pro Tools Software

When launching Pro Tools the first time, you are prompted to enter an authorization code to validate your software.

To validate Pro Tools software:

- 1 Double-click the Pro Tools application in the Pro Tools folder inside the Digidesign folder.
- 2 Enter the authorization code in the dialog when prompted, making sure to observe any spaces, then click Validate.

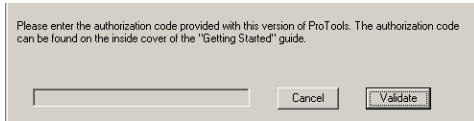

Authorization code validation for Pro Tools

The authorization code is located on the inside cover of your *Getting Started Guide*.

Congratulations! Pro Tools is launched. When Pro Tools is launched for the first time only the menus will appear. To see Edit and Mix windows, a new session must be created. But before you begin working with Pro Tools, you should configure your Pro Tools system settings (see “Configuring Pro Tools” on page 22).

Cannot Create DAE Deck Or Error Number 4

Your computer may not recognize your Pro Tools cards if you did not follow all of the installation steps above.

If you receive error message number 4 or “Cannot Create DAE Deck,” when you launch Pro Tools, complete the following instructions.

To correct a “Cannot Create DAE Deck” error:

- 1 Try re-installing Pro Tools (see “Installing Pro Tools Software” on page 16).
- 2 If that fails, turn your computer off.
- 3 Confirm that all your Pro Tools cards are seated correctly and cables are tightly fastened.
- 4 Start your computer and launch Pro Tools. If the error does not re-appear, you do not need to continue with these steps.
- 5 With your computer on, right-click the My Computer icon (located on your Widows desktop).
- 6 Choose Properties > Hardware > Device Manager.
- 7 Expand the Sound, Video and Game Controllers list.
- 8 In Multimedia Devices, you should see an “!” icon next to each Pro Tools DSP chip that is not properly installed.
- 9 Select one of these “!” icons and press Delete. Click OK in the Confirm Device Remove dialog.
- 10 Repeat the previous step for each of these “!” icons, until they are all removed. Then, click OK.
- 11 Shut down your computer and remove your Pro Tools cards.
- 12 Re-install your Pro Tools cards according to the instructions in “Installing the Pro Tool|HD Cards” on page 11.

Configuring Pro Tools

Configuring the Playback Engine

The Playback Engine sets the voice count (and voiceable tracks) for your system, and it's sessions. Additionally, it lets you customize various System Usage parameters (such as buffers, CPU Usage).

To configure the Playback Engine:

- 1 Choose Setups > Playback Engine.

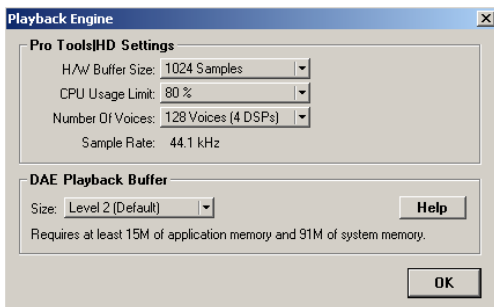

Playback Engine dialog

- 2 From the H/W Buffer Size pop-up, select the audio buffer size, in samples, for host processing tasks such as Real-Time AudioSuite (RTAS) plug-in processing. The default setting is 512 samples. Select a higher setting if you need more buffer time for RTAS, HTDM, and Direct Connect applications.

- 3 From the CPU Usage Limit pop-up, select the maximum percentage of CPU resources to allocate to host processing tasks. The default setting is 40%. Select a higher setting if you need more buffer time for RTAS, HTDM, and Direct Connect applications.

⚠ *Increasing the CPU Usage Limit may slow down screen responses.*

- 4 From the Number of Voices pop-up, select the amount of voices (and voiceable tracks), for your sessions. The default number of voices on a Pro Tools|HD 1 system is 48 voices (at the default 48 kHz sample rate).

⚠ *Changing the number of voices, along with sample rate, affects DSP usage and your system performance. Please read the following carefully.*

Depending on the current sample rate, and the number of HD Core and Process cards in your system, you will have different choices available. For example, each HD card allows you to use one or two of its DSPs per card for voicing.

Most DSP amounts support three levels of voice numbers:

- Select higher voice numbers when your cards are in your machine. You should also select higher voice numbers when using a chassis to run higher track counts at higher sample rates (such as 64 tracks at 96 kHz) and you want more voices (such as 16 voices per DSP at 96 kHz).
- Select medium voice numbers when running cards in an expansion chassis, or when using other PCI cards along with Digidesign cards.
- Select minimum voice numbers if you are running high bandwidth PCI cards (such as video capture).

For voice limits on different HD systems, refer to the *Pro Tools Reference Guide*.

5 From the Sample Rate pop-up, select the session sample rate. This choice will not be available if a session is open.

 *Session sample rate can always be set in the Create a New Session dialog. (See the Pro Tools Reference Guide.)*

6 Set DAE Playback Buffer Size.

The DAE Playback Buffer Size determines the amount of memory allocated within DAE to manage disk buffers, which affects system performance.

Though DAE automatically selects the optimal playback buffer size for your system, you may want to adjust this parameter to modify your system's performance:

- ◆ Allocating a larger buffer size can sometimes allow for a higher density of edits. This can be useful if you experience system performance problems in sessions with a large number of edits in rapid succession. However, choosing a larger buffer size can cause a time lag to occur before playback or recording begins. It can also cause a time lag to occur when you are editing during playback.
- ◆ Allocating a smaller buffer size can sometimes improve playback/recording initiation speed. This can be useful if you are experiencing a time lag when you initiate playback/recording. However, choosing a smaller buffer size can make it difficult for slower hard drives to play or record tracks reliably.

7 Click OK, when finished.

Configuring Hardware Setup (Audio Interfaces)

Pro Tools HD peripherals support 16 channels of simultaneous I/O. The peripherals support multiple formats (such as analog, AES/EBU, TDIF, and so on).

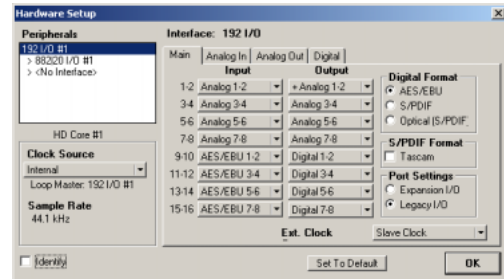

Hardware Setup dialog

The Main page of the Hardware Setup dialog is where you define what physical ports are routed to Pro Tools input and output ports. Think of this window as a patchbay that allows you to route any of the physical inputs or outputs on your HD I/Os to channel assignments in the Pro Tools mixer.

The Main page also provides controls for session Sample Rate, clock settings, and defining whether Expansion Port or Legacy Port peripherals are active.

Additional pages are available to configure other parameters on each I/O (such as setting operating levels).

You must select the peripheral, then set the parameters for that interface—repeating this for each interface in your system.

 *Use the Up and Down Arrow keys to scroll through each peripheral.*

To validate audio interfaces with the Identify button:

- 1 Choose Setups > Hardware in Pro Tools.
- 2 From the Peripherals list, select the Digidesign audio interface connected to the first card in your HD system. This will be the interface at the top of the list.
- 3 Make sure Main page tab is chosen.
- 4 Use the Identify button to verify that your audio interface has been properly identified. Click on the Identify button, located in the lower left corner of the Hardware Setup dialog, to illuminate all the LEDs on the front panel of the audio interface. If the LEDs do not light, make sure the interface is selected in the Peripherals list, and that it is powered on. If the LEDs continue to not light, review hardware installation and run DigiTestHD again.
- 5 Repeat the above steps for additional audio interfaces.

 *Legacy I/Os must be initialized in the Peripherals list before they can be validated with the Identify button. For initialization steps, see “Configuring Legacy I/Os” on page 27.*

To configure audio interfaces:

- 1 Choose Setups > Hardware in Pro Tools.
- 2 From the Peripherals list, select the Digidesign audio interface connected to the first card in your HD system. This will be the interface at the top of the list.
- 3 Make sure Main page tab is chosen.
- 4 To select a different digital I/O on your audio interface (enclosure), click on one of the format buttons, under Digital Format. Choices include: AES/EBU, S/PDIF, and Optical (S/PDIF). Selecting Optical (S/PDIF) resets the physical Optical I/O port (which is, by default, eight channels of ADAT I/O) to two channels of S/PDIF I/O. For more information about HD enclosure and card ports, refer to the guide for your I/O.
- 5 From the Clock Source pop-up, select the appropriate clock source for the system. In most cases, you will use Internal. The other choices are for resolving Pro Tools to external clock sources. Depending on your audio interface, Clock Source options can include: AES/EBU [Encl], S/PDIF, Optical [Encl], AES/EBU 1–8, TDIF, ADAT, and Word clock (optional word clock rates are available at higher frequencies).
- 6 From the Ext. Clock Output, select the appropriate clock source to feed to devices attached to your I/O.

 *If a Legacy audio interface is listed in the Peripherals list (that is, it has been initialized—declared—in Hardware Setup), then the Ext. Clock Output automatically switches to Slave256x. In this case, Ext. Clock Out can only be used for the Legacy I/O. (To set a Legacy I/O to No Interface, select its name in the Peripherals list, then click on No Interface in the Interface pop-up menu.)*

7 For S/PDIF compatibility with Tascam DA30 DAT recorders, click on the Tascam button, under S/PDIF Format.

8 From the input and output channel pop-ups, select the physical ports (such as Analog 1–2, Optical 1–2, and so on), that will be routed to the Pro Tools input and output ports (such as Ch 1–2, 3–4, and so on).

Refer to your peripheral’s guide for sample rate, and other restrictions. For example, the Optical 1–8 channels (on the enclosure) will not be available for session sample rates of 88.2 kHz or higher (whereas the ports on the 192 I/O Digital I/O card will be available).

To differentiate inputs and outputs of the same format, they are labeled differently in the input and output channel pop-ups. For example, the AES/EBU inputs and outputs that come standard in the 192 I/O enclosure are identified as AES/EBU [Encl]; the AES/EBU inputs and outputs that come on the factory-installed Digital port are listed (in pairs) as AES/EBU 1–2, AES/EBU 3–4, and so on. For 192 I/Os equipped with the optional Digital I/O Card, the additional AES/EBU I/O ports on the optional card are labelled AES/EBU 9–10, AES/EBU 11–12, and so on.

9 Configure controls specific to your HD I/O. See “Configuring 192 I/O and 192 Digital I/O Controls” on page 25 and “Configuring 96 I/O Controls” on page 26.

10 For additional HD-series I/Os, choose the I/O in the Peripherals list, and repeat the above steps.

Configuring 192 I/O and 192 Digital I/O Controls

To configure controls specific to a 192 I/O:

1 With the 192 I/O selected in the Peripherals list, click on the Analog In tab for the following options:

- You can set your operating level by selecting Reference Level +4 dBu or –10 dBV, on a channel-by-channel basis, based on which physical inputs are routed to Pro Tools inputs. For more information, see the *192 I/O Guide*.
- Each of the analog channels in the 192 I/O has two Input Trims, labelled A and B, for precisely calibrating and switching levels. Select Input Trim A or B on a channel-by-channel basis. For information on setting the rear panel trims, see the *192 I/O Guide*.
- You can select Soft Clip on a channel-by-channel basis. The Soft Clip limiter attenuates the incoming analog signal, providing extra protection from temporary clipping transients that can cause digital distortion when they exceed the maximum input of the unit. With Soft Clip enabled, 192 I/O supports an additional 4 dB of headroom by rounding off the top 4 dB to the clip point. This is useful for eliminating stray transients or emulating analog tape saturation.

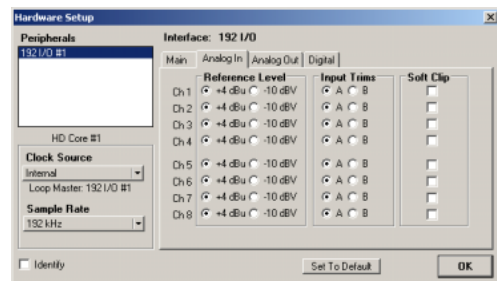

Hardware Setup dialog for 192 Analog In page

2 Click on the Analog Out tab for the following option:

- Each of the analog channels in the 192 I/O has two Output Trims, labelled A and B, respectively. You can select Input Trim A or B on a channel-by-channel basis.

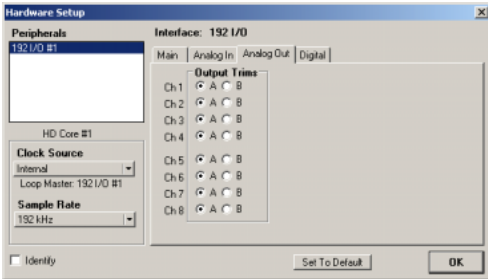

Hardware Setup dialog for 192 I/O, Analog Out page

To configure controls specific to a 192 Digital I/O or 192 I/O with an optional Digital I/O card:

1 On the 192 Digital I/O or 192 I/O with an optional Digital I/O card, click on the Digital tab, to set the Input Format and SR Conversion (real-time sample rate conversion).

 *At session sample rates above 48 kHz, sample rate conversion for the TDIF and Optical (ADAT) inputs on the Digital I/O card is automatically enabled on all eight inputs of the selected format.*

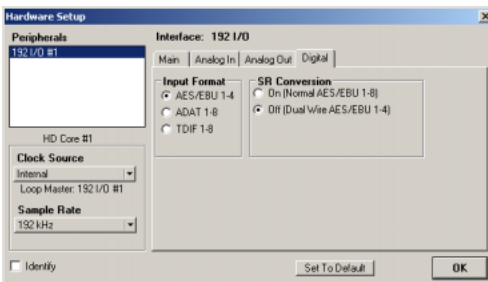

Hardware Setup dialog for 192 I/O, Digital page

Configuring 96 I/O Controls

To configure controls specific to a 96 I/O:

1 With the 96 I/O selected in the Peripherals list, configure your I/O front panel meters for input or output metering from the Meters pop-up.

2 Click on the Analog In tab, for the following option:

- You can set your operating level by selecting Reference Level +4 dBu or -10 dBV, on a channel-by-channel basis, based on which physical inputs are routed to Pro Tools inputs. Refer to the *96 I/O Guide* for more information.

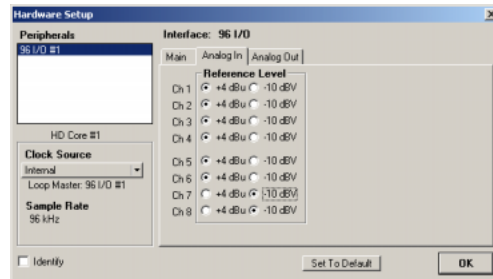

Hardware Setup dialog for 96 I/O, Analog In page

3 Click on the Analog Out tab, for the following option:

- You can set your output level by selecting Reference Level +4 dBu or -10 dBV, on a channel-by-channel basis, based on which physical outputs are routed to Pro Tools inputs. Refer to the 96 I/O Guide for more information.

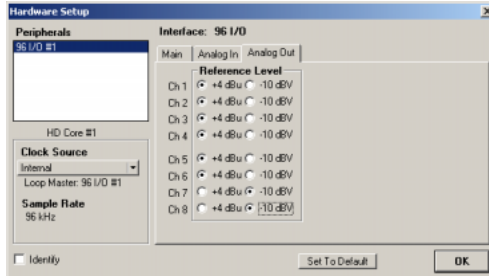

Hardware Setup dialog for 96 I/O, Analog Out page

Configuring Legacy I/Os

Before you can configure a Legacy I/O, it must first be initialized in Hardware Setup.

To initialize and configure a Legacy I/O:

- 1** Before you turn on and configure your Legacy I/O, turn down the volume of output devices. Very loud digital noise may be emitted before the Legacy I/O is initialized.
- 2** Power on your Legacy I/O.
- 3** From the Peripherals list, choose the primary I/O (the audio interface to which you are connecting your Legacy peripheral).
- 4** From the Main page, select the Legacy I/O button in the Port Settings.
- 5** From the Peripherals list, select "> <No Interface>."
- 6** From the Interface pop-up, select your I/O.

7 After the Hardware Setup dialog updates, choose your I/O in the Peripherals list. The Legacy I/O is now ready to be configured.

 For more information on Hardware Setup parameters for each I/O, refer to the peripheral's guide.

Offline Peripherals

When a Legacy I/O and HD peripheral are connected to your primary HD peripheral, only one can be online at a time. An offline peripheral is indicated by brackets in the Peripherals List of the Hardware Setup dialog. For example, if you have a 96 I/O and an 882|20 connected to a 192 I/O, and the 96 I/O is offline, it will appear in the Peripherals List as "[96 I/O]."

Configuring I/O Setup

The I/O Setup dialog provides a graphical representation of the Hardware Setup. Each I/O attached to your system is displayed, with controls to route physical ports to Pro Tools inputs and outputs. These controls mirror the routing controls found in Hardware Setup. Changes made to physical routing in one dialog, are always reflected in the other. I/O Setup also lets you label and map Pro Tools input, output, insert, and bus *signal paths*.

Pro Tools ships with default I/O Setup settings that will get you started. You only need to go to I/O Setup if you want to remap or rename the default I/O paths, or if you alter your HD peripherals in any way (for example, adding an expansion card to a 192 I/O).

 Refer to the Pro Tools Reference Guide for more information on setting up I/O paths.

To configure I/O routing in I/O Setup:

- 1 Choose Setups > I/O Setups in Pro Tools.

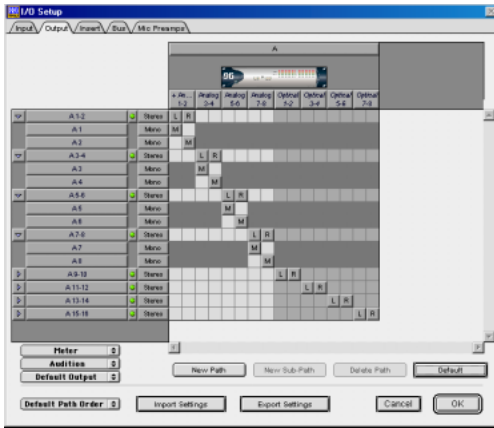

I/O Setup dialog

- 2 Click the Input, Output, Insert, or Bus tab to configure the Input, Output, Insert, or Bus paths for each audio interface.
- 3 Map and name paths as desired.
- 4 If necessary, redefine formats for I/O channels of any peripherals.
- 5 When you have finished, click OK.

Routing a Pro Tools Output Pair to Multiple Audio Interface Output Ports

Pro Tools channel pairs can be routed to multiple outputs on your Digidesign audio interface through Hardware Setup.

This lets you have the same signal (such as a stereo pair, a stem mix, or a multichannel mix) sent to multiple destinations (such as multiple mastering devices). Instead of doing multiple bounces or mix passes, each to a discrete device or output, or daisy-chaining devices, Hardware Setup allows you to “mirror” the Pro Tools output and provide multiple channels of the same signal to different I/O ports. For example, if you

assign Analog 1–2 and Digital [Encl] (AES/EBU, S/PDIF) in Hardware Setup to Pro Tools Output pair 1–2, when you select Pro Tools Output pair 1–2 (as defined in I/O Setup), the audio will be routed to all three outputs with a single dual channel assignment.

Pro Tools output pairs can also be routed to multiple audio interface outputs in I/O Setup.

To select multiple output ports for a Pro Tools output channel pair:

- 1 Choose Setups > Hardware Setup in Pro Tools.
- 2 From the Peripherals list, select the desired interface.
- 3 Make sure Main page tab is chosen.
- 4 Select an output pair.
- 5 Start-click an additional output destination.

The output name updates with a plus sign (“+”) before it.

To verify which output ports have been routed, select the original output: In the pop-up menu, each output assigned to the Pro Tools output channel pair will have a check mark next to it.

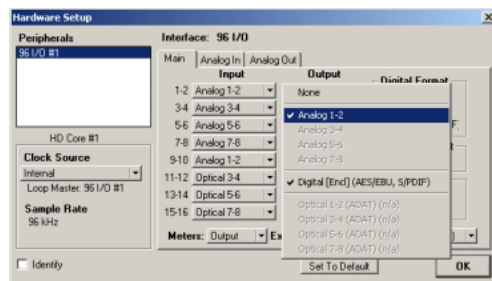

Hardware Setup dialog for 96 I/O, Main page

- 6 Select additional output destinations, as desired. The only limit to output choices is the number of outputs available in your system.

chapter 3

What's New in Pro Tools 5.3.3

This chapter describes the new and changed features in Pro Tools 5.3.3 for Windows XP, as listed below.

- SYNC I/O Features
 - Loop Sync support
 - Auto ID of SYNC I/O
 - Reduced jitter options with LTC
 - Automatic PAL/NTSC Switch
 - 4% pull up pull down
- Improved AVoption|XL Support
 - AVoption|XL supports 25P with FilmFrame option and SYNC I/O
- Support for Avid Unity MediaNetwork 3.1 and MediaManager 3.5
- Support for PRE remote-controlled microphone preamplifier
- Multi-DSP 48-bit Mixer
- Meters on QuickPunch Record-Enabled Tracks
- Overviews stored with exported files

SYNC I/O

Pro Tools 5.3.3 includes several new and improved features available with the Digidesign SYNC I/O synchronization peripheral. The following features are available when using a SYNC I/O with Pro Tools|HD. Complete information can be found in the *SYNC I/O Guide* and the *SYNC I/O Addendum*.

Loop Sync Loop Sync is now supported on the SYNC I/O with Pro Tools|HD systems. This allows the SYNC I/O to be Loop Master and provide master clock to the rest of your HD peripherals.

Auto ID of SYNC I/O When SYNC I/O is connected to the DigiSerial port, Pro Tools automatically detects and identifies itself for SYNC I/O. As part of the automatic identification, Pro Tools checks the firmware in your SYNC I/O and informs you if it needs to be updated.

Reduced Jitter for LTC The LTC In can now be adjusted to any of five different settings to reduce the effects of jitter. These options are available from the Pro Tools Clock Reference > LTC sub-menu.

PAL/NTSC Setting and Video SYNC I/O automatically matches the current session video format, which is set in either of the following ways:

- Manually from the Video Format selector in the Session Setup window
 - or –
- Automatically based on the first frame of an imported video clip

Configuring Sessions for SYNC I/O in Session Setup

When connected to the DigiSerial Port, the SYNC I/O is automatically recognized and configured in Peripherals > Synchronization. This enables the SYNC I/O controls in the Session Setup window.

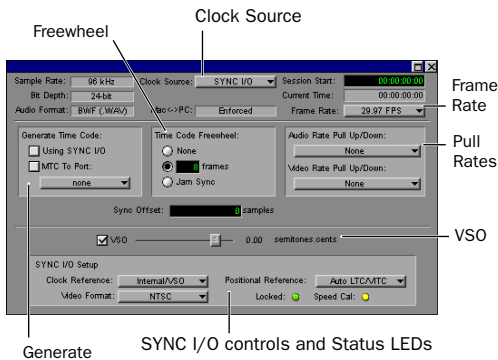

Session Setup window, SYNC I/O controls

When connected through Loop Sync, the SYNC I/O and any of your HD-series audio interfaces can be designated the Clock Source. The current Clock Source determines your choices for clock reference.

To configure the SYNC I/O as the clock source for your sessions:

- 1 Choose SYNC I/O from the Clock Source menu.
- 2 Choose a SYNC I/O clock reference from the Clock Reference menu.
- 3 Choose a positional reference source from the Positional Reference menu.
- 4 Set Frame Rate, Video Format, VSO, Generate, and other SYNC I/O parameters as needed.

SYNC Indicator Lights

Two status lights have been added to the bottom of the SYNC I/O area in the Session Setup window. These lights exactly reproduce their counterparts on the SYNC I/O front panel, letting you monitor the lock status even when the SYNC I/O is located in a machine room.



SYNC I/O status LEDs

Locked When lit, this green LED indicates that the incoming resolve signal is present and that the SYNC I/O is locking to it correctly. When off, the Locked LED indicates that no resolve signal is present.

Speed Cal When lit, this yellow LED indicates whether the resulting sample rate is at the expected (target) rate or not. If lit solid, then the output frequency is within 200 ppm (0.02%) of the selected sample rate. If the output frequency is higher than expected, then Speed Cal will blink quickly; if the output frequency is lower, then it will blink slowly. The Speed Cal LED is meant to be used as an indicator of the accuracy

of the incoming clock reference. For example, if the session is set to 30 fps with LTC as the clock reference but you're actually receiving 29.97 LTC, the Speed Cal LED will blink slowly.

 For more information on all SYNC I/O features, see the *SYNC I/O Guide* and the *SYNC I/O Addendum*.

4% Pull Up and Pull Down

Pro Tools 5.3.3 with SYNC I/O supports 4% pull up and pull down, with support for an additional 0.1% up or down. Separate rates can be set for session audio and video (when video has been imported or captured into the session).

When referring to 4% pull up and pull down, the precise percentages used in pull ups is 4.167%. See “Audio Rates and Pull Up/Down Options” on page 34.

 For more information about 4% pull rates and the *Digidesign SYNC I/O*, see the *SYNC I/O Guide* and the *SYNC I/O Addendum*.

SYNC I/O and 4% Pull Factors

While the SYNC I/O is not required in order to use the extended pull up and down options provided in Pro Tools, the SYNC I/O is the only device that can be controlled from within Pro Tools, and that can recall and restore pull factors automatically when a session opens. Other synchronization peripherals must be configured manually.

 Pull up and down settings do not affect SYNC I/O generated time code.

To enable extended pull up and pull down:

- 1 Choose Setup > Preferences and click the Operation tab.
- 2 Deselect Limit Pull Ups to NTSC/PAL Film Standards.

Choosing a Pull Up/Down Rate

The Pro Tools Pull Up and Pull Down controls are located in the Session Setup window.

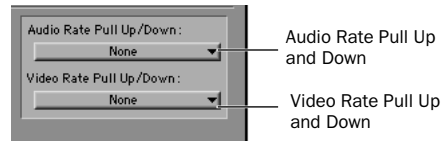

Pull Up/Down menus in the Session Setup window

Audio Rate Pull Up/Down Controls sample rate of audio playback. See “Audio Sample Rate Pull Up and Down” on page 33.

Video Rate Pull Up/Down Controls frame rate of video playback. See “Video Rate Pull Up and Down” on page 35.

The choices available in these menus are determined by the session frame rate. Combinations can be applied by choosing from both menus.

 4% pull factors are not available in 176.4 and 192 kHz sessions.

Enabling Extended Pull Up and Down Options

New Preference and Session Setup Controls

With Pro Tools 5.3.1 on Windows, the Limit Pull Ups to NTSC Film Standards preference was introduced. This setting filtered the list of available Pull Up rates in the Session Setup window to NTSC standard rates.

This preference setting has been renamed as Limit Pull Ups to NTSC/PAL Film Standards, and is enabled by default. See “When Limit Pull Ups is Enabled” on page 33 for a list of available rates at the default, enabled setting.

When this preference is not enabled, the Audio Rate Pull Up and Down menu offers all possible combinations of pull ups and pull downs for the audio sample rate, regardless of the session frame rate.

In addition, if there is a QuickTime video clip in the timeline, turning this preference off enables the video rate to be pulled up or down by 0.1%, regardless of the session frame rate. Though not an approved workflow, earlier versions of Pro Tools also enabled pull down of QuickTime video clips when audio was pulled down, so this option is included in Pro Tools 5.3.3 to maintain compatibility with earlier sessions.

The choice of available pulls for Avid video clips is unaffected by the setting of the Limit Pull Ups to NTSC/PAL Film Standards preference.

This preference setting is stored with the session.

Auto Match Pull Factors

Auto Match Pull Factors is available from the session Frame Rate menu in the Session Setup window (directly below the Current Time Code counter). When Auto Match Pull Factors is enabled, Pro Tools adjusts audio and video playback rates as needed to match any changes to the current session Frame Rate.

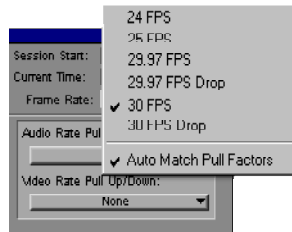

Frame Rate menu with Auto Match Pull Factors

Auto Match Pull is applied relative to the current pull up setting. While enabled, if the session frame rate is changed in such a way that the video would have to be pulled by an unsupported amount, the video remains unaffected. The Audio Rate Pull Up/Down and Video Rate Pull Up/Down menus become unavailable (greyed out) when Auto Match Pull Factors is enabled.

This setting is latching, is not enabled by default, and its state is stored with the session. In addition, Auto Match Pull Factors is not affected by the current setting of the Limit Pull Ups to NTSC/PAL Film Standards preference.

Example of Auto Match Pull Factors

Auto Match Pull Factors links audio and video pull factors when changing session frame rate.

For example, assume a Pro Tools session is set to a frame rate of 25 fps, the audio and video are both playing with no pull ups, and Auto Match Pull Factors is enabled.

If you then change the session Frame Rate to 24 fps, both the Audio and Video Rate Pull settings would change by -4.0% (the appropriate pull setting required by the change in frame rate).

Auto Match-enabled pull factors are applied to any existing Audio Rate Pull Up/Down or Video Rate Pull Up/Down settings. For example, if audio was already being pulled -0.1% when you changed the session Frame Rate from 29.97 to 24 fps, then the Audio Rate Pull Up/Down menu would switch to “none.”

Audio Sample Rate Pull Up and Down

The Audio Rate Pull Up/Down menu applies pull up or down factors to session audio record and playback. Choices are determined by the Limit Pull Up to NTSC/PAL Film Standards preference. See “Enabling Extended Pull Up and Down Options” on page 32.

When Limit Pull Ups is Enabled

When Limit Pull Ups to NTSC/PAL Film Standards is enabled, the following choices are available depending on the current session rate.

NTSC/PAL Choices for Pull Up and Pull Down

Session Frame Rate	Audio Rate Pull Up/ Down
24 fps	None +0.1% (Source = 23.98/29.97 fps) -4% (Source = 25 fps)
25 fps	None +4.167% (Source = 23.98/29.97 fps) +4.167% (Source = 24/30 fps)
29.97/29.97 fps drop frame	None -0.1% (Source = 24/30 fps) -4% (Source = 25 fps)
30/30 fps drop frame	None +0.1% (Source = 23.98/29.97 fps) -4% (Source = 25 fps)

When Limit Pull Ups is Not Enabled

When Limit Pull Ups to NTSC/PAL Film Standards is not enabled, all pull rates are available, regardless of session frame rate.

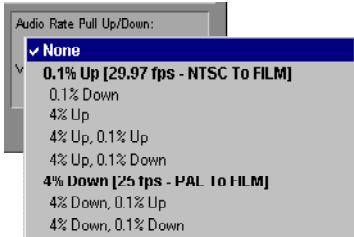

Audio Rate Pull menu when Limit Pull Ups is not enabled

 See also “Auto Match Pull Factors” on page 32.

Audio Rates and Pull Up/Down Options

Table 1 lists the actual sample rates of each pull up and pull down option and combination (rounded to the nearest whole Hz):

Table 1. Sample Rates at Pull Up and Pull Down Settings

Pull Up/Down	Sample Rate (Hz)					
	44100	48000	88200	96000	176400	192000
+4.1667% and +0.1%	45983	50050	91967	100100	n/a	n/a
+4.1667%	45938	50000	91875	100000	n/a	n/a
+4.1667% and -0.1%	45892	49950	91783	99900	n/a	n/a
+0.1%	44144	48048	88288	96096	176576	192192
-0.1%	44056	47952	88112	95904	176224	191808
-4.0% and +0.1%	42378	46126	84757	92252	n/a	n/a
-4.0%	42336	46080	84672	92160	n/a	n/a
-4.0% and -0.1%	42294	46034	84587	92068	n/a	n/a

Video Rate Pull Up and Down

This menu lets you change the frame rate of video playback independently from the audio pull-ups (if any). It is located below the Audio Rate Pull Up/Down menu in the Session Setup window.



Video Rate Pull Up/Down menu in Session Setup

The choices available in the Video Rate Pull Up/Down menu depend on the file format of the video clip, as well as its frame rate. The following table shows the pull ups available for Avid video clips, both interlaced and Progressive Scan.

Video Frame Rates and Pull Options

Format and Video Frame Rate	Available Video Pull Rate	To synchronize with
Avid Video		
24 fps	None	
	-0.1%	29.97 NTSC videotape
	+4.167%	25 fps PAL videotape
25 fps	None	
	-4.0%	24 fps
	+4.167%	29.97 NTSC videotape
29.97	None	

Video pull rates are saved with the session.

 See also "Auto Match Pull Factors" on page 32.

Pull Ups and QuickTime

No pull ups are available for Quicktime video clips unless you turn off the preference Limit Pull Ups to NTSC/PAL Film Standards, located in the Operations pane of the Preferences dialog. Turning this preference off allows the video rate to be pulled up or down by 0.1%, regardless of the session frame rate. Though not an approved workflow, earlier versions of Pro Tools also enabled pull down of QuickTime video clips when audio was pulled down, so this option is included in Pro Tools 5.3.3 to maintain compatibility with earlier sessions.

No Video Recording with Pull Ups

Video may not be recorded to the timeline if a video pull up is selected. If the video track is record enabled while video pull ups are enabled, or if you attempt to set a video pull up rate while the video track is record enabled, Pro Tools will post a dialog and disallow video recording. To proceed with digitization, reset the Video Rate Pull Up menu to None.

What is Pulled Up or Down?

The following sections describe how related Pro Tools features are affected by pull up and down rates.

Time Code Ruler

Video pull up and down does *not* affect the Time Code Ruler. Be sure to set the session Frame Rate to the correct frame rate for your project. For example, if working with 24 fps video and you pull the video up by 4%, switch the session Frame Rate to 25 fps to keep the Time Code Ruler aligned. Similarly, if working with 24 fps video that is pulled down by 0.1%, switch the frame rate of the session to 29.97.

When working with 25 fps Avid media and the video is set to pull down by 4%, set the session Frame Rate to 24 fps.

Plug-Ins

For proper operation at larger (4%) pull rates, plug-ins must utilize sample clock instead of an absolute time clock. All Digidesign plug-ins are based on sample clock.

Higher Sample Rates and Pull Factors

4% audio pull rates are not available in 176.4 and 192 kHz sample rates sessions.

25P

Pro Tools 5.3.3 on Pro Tools|HD systems introduces support for 25P playback of Avid video with SYNC I/O, AVoption|XL, and FilmFrame option.

24P and 25P Avid Video Playback Capability

AVoption|XL with FilmFrame plays back 24P (progressive scan) and 25P format video files imported from Avid editing systems. 24P and 25P files may be played and edited, just like video clips in other formats, but they cannot be recorded directly to the Pro Tools Timeline.

To play back 24P or 25P format video files, you will need:

- ◆ Pro Tools 5.3.3 software
- ◆ SYNC I/O
- ◆ AVoption|XL
- ◆ FilmFrame option

FilmFrame

FilmFrame enables AVoption|XL to play back 25P in addition to 24P video clips. FilmFrame also enables AVoption|XL to play back 24 fps and 25 fps interlaced video clips.

When using FilmFrame, all clips in the Movie track should be either 24 fps or 25 fps. This is because the first frame in the Movie track sets the video engine to the appropriate speed. If the first clip is 24 fps, the entire Movie track will play at 24 fps; or, if the first clip is 25 fps, the entire Movie track will play at 25 fps.

Avid Unity Support

Pro Tools 5.3.3 on Pro Tools|HD systems introduces support for Avid Unity MediaNetwork 3.1 and MediaManager 3.5. Pro Tools 5.3.3 continues support for Avid Unity MediaNet 3.0 and MediaManager 3.0.

 *For the most current compatibility information on supported Pro Tools systems and Avid Unity MediaNetwork, refer to the Digidesign Web site (www.digidesign.com).*

Avid Unity MediaNetwork

Designed specifically for dynamically storing and sharing high-bandwidth, high-resolution media, the Avid Unity MediaNetwork solution offers significant performance, setup, and administrative advantages over standard storage area networks (SANs). Built on Avid's custom-designed, highly optimized file system architecture, Avid Unity MediaNetwork delivers a full range of uncompressed and compressed media in real time, while enabling editing, finishing, audio, and graphics work to take place at the same time—using the same media files and projects—in a shared workspace.

On a Pro Tools Windows XP client, use the Avid Connection Manager to log in to MediaNetwork. MediaNetwork workspaces function like normal network volumes. Your Avid Unity MediaNetwork administrator will assign the username and password for your account, as well as assign Read or Read/Write permissions for your account on each workspace.

Your MediaNetwork username and password should be the same as your Windows username and password. If you are connected to a separate network (such as a local area network by ethernet), it is recommended that you use the same username and password for MediaNetwork and the other network.

Once you log in to MediaNetwork on a Windows client, you remain logged in, so you really only need to log in once—the first time. Shut Down or Log Off Windows to log off Windows and MediaNetwork. The next time you log in to Windows you will automatically be logged in to MediaNetwork as well.

Configuring the Avid Unity MediaNetwork Connection Manager

To configure the Avid Connection Manager:

1 In the Avid Connection Manager, choose Configure.

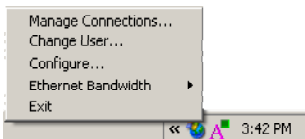

Avid Connection Manager

2 In the Configuration dialog, click Advanced.

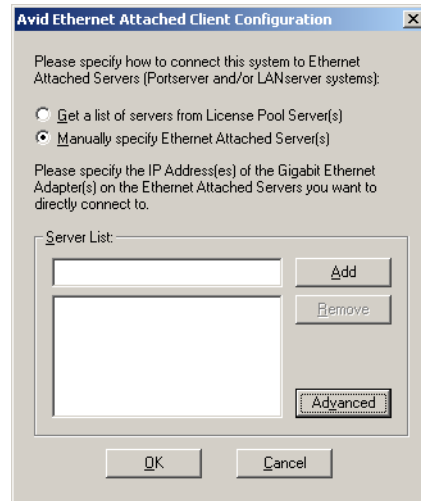

Avid Connection Manager

3 In the Advanced Connection Manager Options dialog, select the starting drive letter for MediaNetwork workspaces.

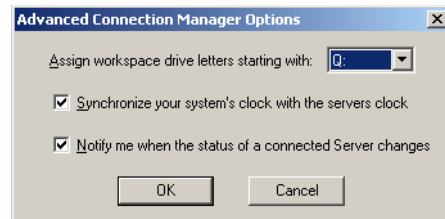

Avid Connection Manager

4 Select “Synchronize the system clock with the Server clock.” This is necessary to help prevent time-related title creation and access problems by synchronizing the MediaNetwork client time to the MediaNetwork File Manager time.

5 Select “Notify me when the status of a connected Server changes.”

6 Click OK to close the Advanced Connection Manager Options dialog.

7 Click OK to close the Configuration dialog.

Avid Unity MediaManager

Avid Unity MediaManager allows you to find, sort, and retrieve media quickly and easily while maintaining secure project-level access control. MediaManager also allows your production assistants and others who manage media to do their jobs outside of the edit suite, ensuring that creative work continues while administrative duties take place in parallel. Tightly integrated with Avid applications, Pro Tools, and other productivity tools, MediaManager enables management of assets from a central location outside of the edit suite.

Pro Tools with DigiTranslator 2.0 includes integrated support for MediaManager, including check-in of files, and drag and drop of files or sequences from the MediaManager Browser directly to the Pro Tools timeline. DigiTranslator is required for MediaManager support, but it is not required for Avid Unity MediaNetwork.

 For the latest Web browser requirements for MediaManager, refer to the Digidesign Web site (www.digidesign.com) or Avid Web site (www.avid.com).

PRE Remote Controlled Microphone Preamplifier

Pro Tools 5.3.3 supports PRE, the latest new peripheral for Pro Tools|HD systems.

PRE is Digidesign's multi-purpose microphone preamplifier for Pro Tools systems. PRE is designed especially for Pro Tools systems, but it can also be utilized as a stand-alone microphone preamplifier. When used with Pro Tools TDM 5.3.3 on Windows XP, most PRE features can be controlled from within the Pro Tools application. PRE can also be remotely controlled by

other MIDI devices through standard MIDI controller data. With or without remote control, PRE can be configured manually using its front panel switches and displays.

Features

- Eight high-performance, discrete matched transistor hybrid microphone preamplification circuits; 0 dB to +66 dB in 3 dB steps.
- Full remote control via Pro Tools TDM 5.3.3 software and Digidesign control surfaces (such as Control|24 and ProControl), allowing for the highest fidelity by keeping preamplification of low-level signals close to the source.
- Analog outputs (DB-25 connector) for easy connection to Pro Tools audio interfaces or any other recording or mixing medium.
- MIDI In, Out, and Thru ports for remote operation
- Each PRE channel features:
 - Support for Mic (XLR), line level inputs (1/4") and direct instrument (1/4")
 - Selectable impedance settings for Mic input
 - +48V power for condenser microphones
 - Insert points (Send and Return), for easy integration of outboard gear (such as compressors or EQs)
 - Input gain -18 dB pad
 - Phase reversal
 - 75 Hz High-Pass Filter
- Up to nine PREs are supported through software or 72 channels of remote controlled mic-pre channels
- All features are available in Stand-alone mode, making PRE ideal for any recording application.

Configuring Pro Tools to Use PRE

Installation of PRE remote control in Pro Tools includes:

- Making audio and MIDI connections to PRE
- Configuring Pro Tools:
 - Declaring PRE in the Peripherals dialog.

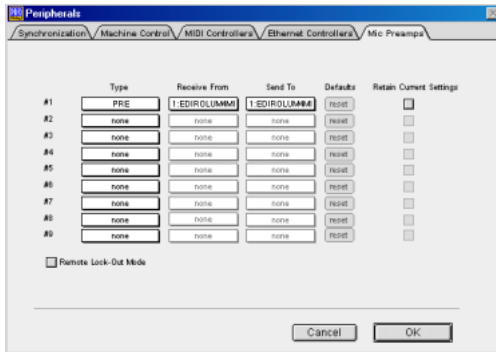

Peripherals dialog, Mic Preamps tab

- Mapping PRE outputs to an audio interface's inputs in the I/O Setup dialog.

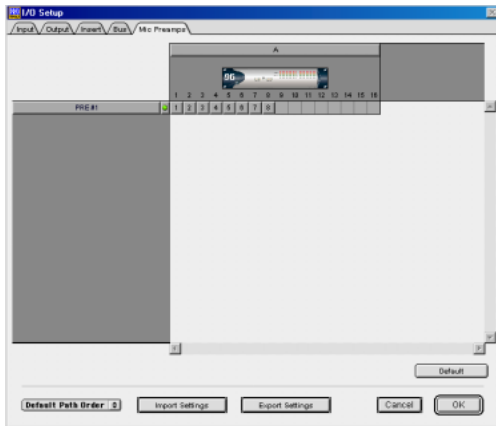

I/O Setup dialog, Mic Preamps tab

Once PRE is configured in Pro Tools, Mic Preamp controls can be displayed in Pro Tools Mix and Edit windows, and you can:

- Remote control PRE from the Mix or Edit window.
 - or –
- Use PRE front panel controls to adjust Mic Preamp controls in Pro Tools.

 For detailed information on installing, configuring, and using PRE with Pro Tools, see the PRE Guide.

Multi-DSP 48-bit Mixer

Pro Tools 5.3.3 includes four new “multi-DSP” high-resolution mixers.

- Stereo Mixer
- Stereo Dithered Mixer
- Surround Mixer
- Surround Dithered Mixer

These mixers utilize multiple TDM paths to maintain a true 48-bit signal path at all times, regardless of the complexity of your mix. This is particularly beneficial for maintaining headroom when mixing load is shared between DSPs on Pro Tools|HD systems.

The following tables show the largest mixers that can fit on a single HD DSP chip:

Stereo Mixer

Sample Rate	Largest Mixer per Chip
44.1/48 kHz	68x2
88.2/96 kHz	44x2
176.4/192 kHz	16x2

Stereo Dithered Mixer

Sample Rate	Largest Mixer per Chip
44.1/48 kHz	56x2
88.2/96 kHz	34x2
176.4/192 kHz	14x2

Surround Mixer (5.1 output)

Sample Rate	Largest Mixer per Chip
44.1/48 kHz	22x6
88.2/96 kHz	12x6
176.4/192 kHz	4x6

Surround Dithered Mixer (5.1 output)

Sample Rate	Largest Mixer per Chip
44.1/48 kHz	19x6
88.2/96 kHz	10x6
176.4/192 kHz	1x6

The following tables list the maximum numbers of Pro Tools tracks or inputs that can be mixed to a single pair of outputs, no matter how many DSPs or timeslots are available.

Stereo Mixers, maximum limits

Sample Rate	Mixer Capacity
44.1/48kHz	512x2
88.2/96kHz	484x2
176.4/192kHz	64x2

5.1 Surround Mixers, maximum limits

Sample Rate	Mixer Capacity
44.1/48kHz	512x6
88.2/96kHz	256x6
176.4/192kHz	32x6

⚠ *It is possible to reach these mixer limits even if the System Usage Window indicates that you still have mixer DSP and/or TDM II timeslots available.*

Meters and QuickPunch Record Enabled Tracks

When a track is QuickPunch record-enabled, on-screen meters now reflect the level of the audio playing from disk. At punch-in, the meter switches to display the input signal level, and switches back to meter the disk audio on punch out. (In earlier versions of Pro Tools, meters were inactive on QuickPunch record-enabled tracks until punch in.)

Calculate Overviews for Exported Files

Pro Tools calculates waveform overviews and stores them as part of the file, in all audio files created by bouncing to disk or exporting (OMFI or not).

However, if you Convert During Bounce, Pro Tools will not calculate and store overviews because this CPU-intensive procedure may slow the bounce function.

chapter 4

What's New in Pro Tools TDM 5.3.1

Following is an overview of new and changed features included with Pro Tools TDM 5.3.1 on Windows. For more details on each feature, refer to specific product guides, where indicated.

▲ *Pro Tools TDM 5.3.1 features discussed in this chapter support Pro Tools|HD, Pro Tools|24 MIX, and Pro Tools|24 systems on Windows.*

Support for Pro Tools|HD Hardware

Pro Tools 5.3.1 adds support for Digidesign's new Pro Tools|HD cards and interfaces on Windows XP Home and Professional Editions. Pro Tools|HD features high definition audio with higher sampling rates, increased track count, more DSP, and enhanced TDM II mixing capabilities.

Pro Tools|HD hardware comes in three configurations:

Pro Tools|HD 1 Includes a single HD Core card.

Pro Tools|HD 2 Includes an HD Core card, an HD Process card, and a TDM FlexCable for connecting the HD Core to the HD Process card.

Pro Tools|HD 3 Includes an HD Core card, two HD Process cards, and two TDM FlexCables.

The HD Core Card

The HD Core card provides up to 96 tracks of direct-to-disk recording and playback, and 32 channels of I/O to your Pro Tools HD-series system, as well as DSP power for processing and mixing. The HD Core card supports up to 24-bit and up to 192 kHz sessions.

The HD Process Card

The HD Process card provides DSP power for mixing, processing, and DSP software such as the DigiRack plug-ins included with Pro Tools. It also provides a DigiLink port for connecting up to 32 additional channels of I/O. The HD Core card supports up to 24-bit and up to 192 kHz sessions.

High Definition Audio

Pro Tools 5.3.1 supports high definition, 24-bit audio with sample rates up to 192 kHz when used with a 192 I/O (or 192 Digital I/O) audio interface or up to 96 kHz when used with a 96 I/O audio interface. Supported sample rates include 44.1, 48, 88.2, 96, 176.4, and 192 kHz.

Increased Voice and Track Count

Pro Tools 5.3.1 provides up to 96 simultaneous voices of audio at 44.1 or 48 kHz from a single HD Core card, with a maximum of 112 voiceable tracks (previously known as virtual voicing).

Pro Tools|HD 2 and Pro Tools|HD 3 systems provide up to:

- 128 tracks at 44.1 or 48 kHz
- 64 tracks at 88.2 or 96 kHz
- 24 tracks at 176.4 or 192 kHz

New TDM II Mixing Architecture

Pro Tools 5.3.1 supports TDM II, a new mixing architecture designed for Pro Tools|HD hardware. At a minimum, TDM II provides twice as many time slots (512 at 44.1/48 kHz) as Pro Tools|24 MIX and Pro Tools|24 systems, and hence a greater potential number of connections for routing, processing and mixing audio signals within Pro Tools. This allows for extremely large mixing configurations, which are particularly useful in surround mixing projects.

Support for 192 Digital I/O, 192 I/O, and 96 I/O

Pro Tools 5.3.1 adds support for Digidesign's new high-resolution 192 Digital I/O, 192 I/O, and 96 I/O audio interfaces.

192 Digital I/O

The 192 Digital I/O provides sixteen simultaneous channels of high-resolution, 24-bit digital audio input and output at sample rates of up to 192 kHz.

192 Digital I/O Features

- Sixteen channels of AES/EBU I/O (8 channels at 192 kHz)
- Real-Time Sample Rate Conversion on input
- Sixteen channels of TDIF I/O (up to 48 kHz)
- Sixteen channels of ADAT I/O (up to 48 kHz)
- Two additional channels of AES/EBU or S/PDIF (up to 96 kHz)
- Eight additional channels of ADAT optical, or two channels of optical S/PDIF
- Word Clock I/O
- Loop Sync I/O
- Expansion and Legacy Ports
- Sixteen channels of 4-segment metering, plus Status indicators

192 I/O

The 192 I/O provides sixteen simultaneous channels of high-resolution, 24-bit audio input and output at sample rates of up to 192 kHz, and has an I/O expansion bay for adding more analog inputs, analog outputs, or digital I/O.

192 I/O Features

- Sixteen discrete channels of input and output, with 4-segment LED Meters to monitor input and output on each channel. Input and Output channels can include:
 - Eight channels of 24-bit D/A and A/D converters for superior analog input and output at sampling rates of 44.1, 48, 88.2, 96, 176.4, and 192 kHz
 - Eight channels of AES/EBU I/O (four channels at 192 kHz)
 - Sixteen channels of Optical I/O, through two pairs of Lightpipe (ADAT) connectors; one pair of optical ports can be switched to two channels of optical S/PDIF I/O

- Two additional channels of AES/EBU or S/PDIF (up to 96 kHz)
- Real-time sample rate conversion on inputs of eight channels of either AES/EBU, Optical, or TDIF
- Word Clock input and output for synchronizing 192 I/O with external Word Clock or 256x (Slave Clock) devices
- Simultaneous use of up to eight 192 I/O units is supported, for a maximum of 96 channels of analog I/O at 96 kHz
- Legacy Port for Digidesign MIX-series audio interfaces
 - Sixteen channels of Optical I/O, through two pairs of Lightpipe (ADAT) connectors; one pair of optical ports can be switched to two channels of optical S/PDIF I/O
 - Two additional channels of AES/EBU or S/PDIF (up to 96 kHz)

96 I/O

The 96 I/O provides sixteen simultaneous channels of high-resolution, 24-bit audio input and output at sample rates of up to 96 kHz.

96 I/O Features

- Sixteen discrete channels of input and output, with 4-segment LED Meters on each channel. Input and Output channels can include:
 - Eight channels of 24-bit D/A and A/D converters for superior analog input and output at sampling rates of 44.1, 48, 88.2, and 96 kHz
 - S/PDIF, AES/EBU, and Optical (ADAT) digital inputs and outputs
- Word Clock input and output for synchronizing 96 I/O with external Word Clock or 256x (Slave Clock) devices
- Simultaneous use of up to six 96 I/O units, for a maximum of 96 channels of analog and digital I/O at 48 kHz

- Legacy port for Digidesign MIX-series audio interfaces
 - Sixteen channels of Optical I/O, through two pairs of Lightpipe (ADAT) connectors; one pair of optical ports can be switched to two channels of optical S/PDIF I/O
 - Two additional channels of AES/EBU or S/PDIF (up to 96 kHz)

Optional Legacy I/O Audio Interfaces

For additional input and output channels, older Digidesign audio interfaces (referred to as “Legacy” I/Os) can be connected to the 192 I/O or 96 I/O. Legacy interfaces can only be used with 44.1 or 48 kHz sessions. Additionally, Legacy audio interfaces are not automatically sensed in the Hardware Setup dialog and must be manually identified.

Legacy interfaces include:

- 888|24 I/O
- 882|20 I/O
- 1622 I/O
- Digidesign 24-bit ADAT Bridge I/O and ADAT Bridge I/O

Support for DigiLink Connections

New DigiLink proprietary I/O interconnect cables make the vital connection between HD Core or HD Process cards and HD I/Os. These cables support 32 channels of I/O per card and up to 96 total channels of I/O between multiple HD I/Os.

Support for SYNC I/O

Pro Tools 5.3.1 adds support for Digidesign's new SYNC I/O on Pro Tools|HD and Pro Tools|24 MIX systems. SYNC I/O is not supported on Pro Tools|24 systems. SYNC I/O is a multi-purpose synchronization peripheral that provides most all of the functions and connections needed to achieve synchronization to a variety of devices.

SYNC I/O lets you synchronize Pro Tools to LTC, VITC, and Bi-Phase/Tach, or internal for positional reference (time code), and supports all major clock references. SYNC I/O can also generate LTC, VITC, and Bi-Phase/Tach.

SYNC I/O offers extremely fast lockup, near sample-accurate synchronization, and an exceptionally low-jitter clock. These features provide professional performance and maximum audio fidelity under a wide range of synchronization conditions.

 For information on SYNC I/O, see the *SYNC I/O Guide and Addendum*.

Software Enhancements

Pro Tools 5.3.1 features a variety of software enhancements for configuring Pro Tools|HD, Pro Tools|24 MIX, and Pro Tools|24 hardware and managing sessions.

Hardware Setup

A new Hardware Setup dialog provides comprehensive controls for configuring all connected audio interfaces and peripherals, as well as global settings such as the Clock Source for the peripherals connected to the system.

Connected 192 I/O and 96 I/O audio interfaces, and the cards to which they are attached, are automatically sensed and identified by Pro Tools 5.3.1 software, eliminating the need to manually define these connections.

Legacy audio interfaces (such as the 888|24 I/O or 882|20 I/O) are not automatically sensed and must be manually identified within this dialog.

 *Legacy interfaces cannot be used in sessions with sample rates above 48 kHz.*

The Main page of the Hardware Setup dialog is used to define what physical ports are routed to Pro Tools input and output ports. Each connected 192 I/O and 96 I/O has its own Main page that allows you to define the format, on a pair-by-pair basis, of the 16 channels of I/O that are usable by Pro Tools

The Main page also provides controls for system Sample Rate, Sync settings, and defining whether Expansion Port or Legacy Port peripherals are active.

Additional pages configure other parameters on each I/O, such as setting operating levels. For more information, refer to the *Getting Started with HD Guide* and the guide for your specific interface.

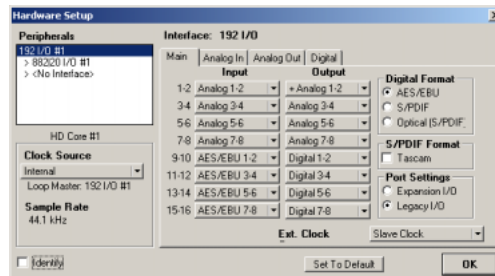

Hardware Setup dialog

I/O Setup

The I/O Setup dialog supports the new Pro Tools|HD hardware and provides comprehensive controls for configuring the signal paths of all connected interfaces.

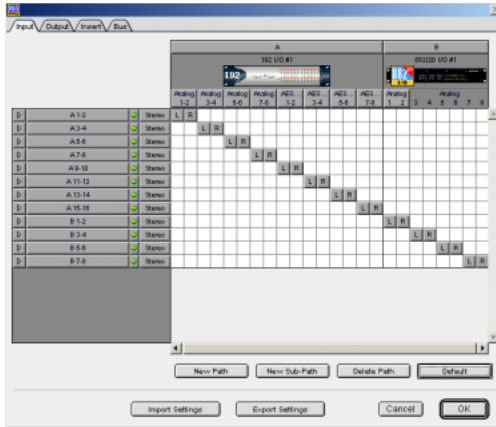

I/O Setup dialog

Playback Engine

The Playback Engine dialog has been streamlined. It can now be opened without requiring that the current session be closed. In addition, the Playback Engine dialog now has controls for setting the DAE Playback Buffer Size, a control previously found in the DAE application.

A new Number of Voices pop-up menu allows you to choose the number of voices in a session and the number of DSP chips used to provide those voices (and thus the number of voices per DSP) and the number of DSP chips assigned as Playback Engine chips. Depending on the current session sample rate, and the number of HD Core and Process cards in your system, you will have different choices available. Changing the number of voices or session sample rate affects DSP usage and your system performance. Up to four DSP chips can be used as Playback Engine chips.

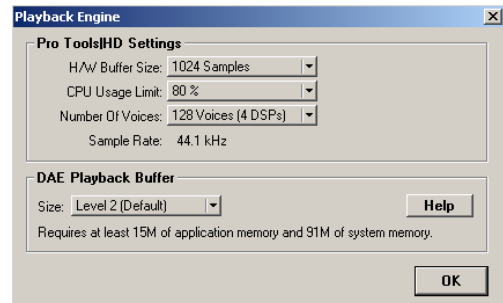

Playback Engine dialog

Disk Allocation Dialog Shortcuts

Two new key shortcuts make it easier to allocate a specific destination hard drive to multiple tracks simultaneously:

- To make a continuous selection, Shift-click a track name (in the Track column) to extend the selection to include already-selected tracks and all tracks in between.
- To make a non-contiguous selection, Command-click (Macintosh) or Control-click (Windows) a track name in the Track column to extend the selection to include already-selected tracks without including tracks in between.

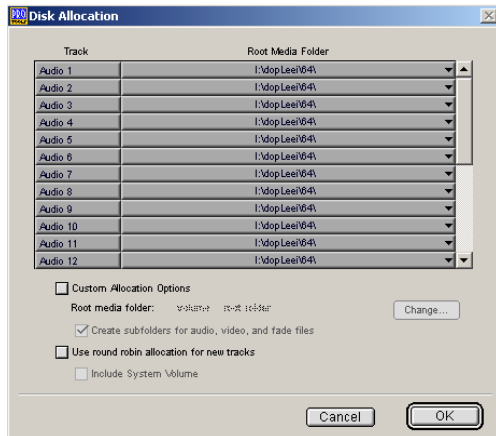

Disk Allocation dialog

Bounce to Disk

Bounce to Disk now supports bouncing at high definition sample rates. Supported destination sample rates include 44.1, 48, 88.2, 96, 176.4, and 192 kHz. Pull Up/Pull Down variants for all supported standard sample rates are also provided.

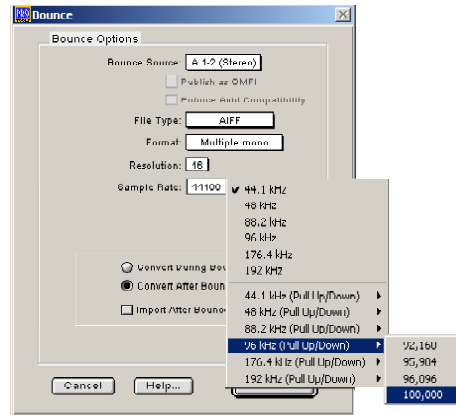

Bounce to Disk dialog

New Session

The New Session dialog now supports Pro Tools|HD's high definition sample rates. Supported sample rates include 44.1, 48, 88.2, 96, 176.4, and 192 kHz. The session sample rate is defined in the New Session dialog when a session is first created.

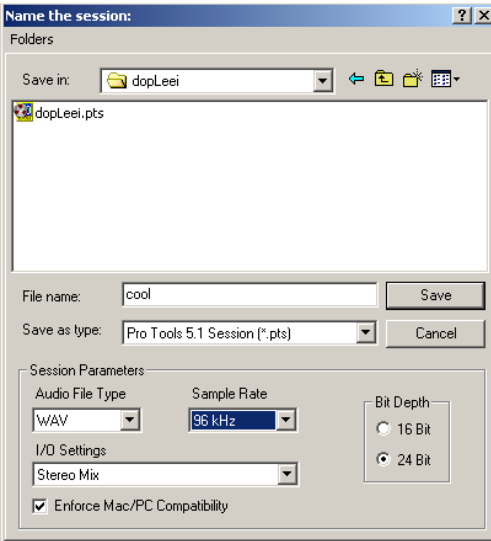

New Session dialog

Save Session Copy In

The Save Session Copy In dialog allows saving a copy of the current session in the following formats:

- Latest (Pro Tools 5.1 or later)
- Pro Tools 5 Session
- Pro Tools 4, 16-Bit Session
- Pro Tools 4, 24-Bit Session
- Pro Tools 3.2 Session

Choose Latest if you are working with Pro Tools software version 5.1 or higher.

⚠ *When a Pro Tools 5.3.1 session is saved to an earlier version, multichannel tracks and multi-mono plug-ins are lost. To preserve these, separate the tracks and plug-ins to individual mono tracks before saving a copy of the session.*

Opening 5.3.1 Sessions Using Earlier Versions of Pro Tools

If you want to use an earlier version of Pro Tools to open a 5.3.1 session containing audio files with sample rates above 48 kHz, choose the “Save Session Copy In” command and resave the session and its audio files to either a 44.1 or 48 kHz sample rate.

Display Mac/PC Compatibility Mode

The Session Setup Window displays whether Mac/PC Compatibility is enabled or not for the current session.

If a session was created in Mac/PC Compatibility mode (set in the New Session window) Mac <-> PC: Enforced will be displayed in the Session Setup window.

If the session is not Mac/PC compatible, Mac <-> PC: Not Enforced will be displayed in the Session Setup window.

New TDM Mixer Plug-Ins

Pro Tools 5.3.1 provides four different Mixer plug-ins to support high definition audio on Pro Tools|HD systems. These new Mixer versions are: Stereo, Surround, Stereo Dithered, and Surround Dithered.

The Stereo and Surround Mixer plug-ins are installed by default. When you run the Pro Tools Installer, a copy of the Stereo Dithered and Surround Dithered mixers are placed in the folder “Plug-Ins (Unused)” inside the DAE folder.

Standard Surround and Stereo Mixers

Both the Surround and Stereo Mixer plug-ins provide the following:

- ◆ 24-bit digital output, from an audio interface output or the Bounce to Disk function. Mix level scaling stores 48-bit results, using a 56-bit accumulator for maximum precision.
- ◆ 48 dB of mix headroom
- ◆ Output clip indication
- ◆ Multichannel mixing formats for surround (available with the Surround Mixer)

Surround Dithered and Stereo Dithered Mixers

Both the Surround Dithered and Stereo Dithered Mixer plug-ins provide the following:

- The same features as the standard Stereo and Surround mixers, with the addition of non-correlated dither to any output or bus send.

Switching TDM Mixer Plug-Ins

In most cases, the Mixer plug-in that was automatically installed with your system is the best one for all around use. However, you can switch Mixer plug-ins, if necessary.

To Switch TDM mixer plug-ins:

- 1 Quit Pro Tools.
- 2 Open the DAE Folder. The DAE folder is installed at the root level of the System Folder.
- 3 Open the “Plug-Ins (Unused)” folder, locate the Mixer plug-in that you want to use, and drag it to the Plug-Ins folder.
- 4 Open the Plug-Ins folder, locate the mixer plug-in version that you no longer wish to use, and drag it to the “Plug-Ins (Unused)” folder.
- 5 Launch Pro Tools.

Plug-In and Processing Features

Pro Tools 5.3.1 adds new plug-ins and DSP-processing related enhancements. All DigiRack Plug-Ins support up to 192 kHz session sample rates.

New DigiRack Plug-Ins

Pro Tools 5.3.1 includes new DigiRack plug-ins with the following enhancements:

- A new Mod Delay II plug-in with Tempo, Meter, and note-based entry of delay time
- An RTAS version of POW-r Dither
- TDM and RTAS versions of Digidesign’s D-Verb plug-in
- Three separate TimeAdjuster plug-ins (Short, Medium, Long) for a wider variety of sample delay times

Mod Delay II Plug-In

Mod Delay II for Pro Tools 5.3.1 adds controls for Tempo, Meter, Duration, and Groove.

Tempo Sets the desired tempo in beats per minute (bpm).

Meter Allows you to enter simple or compound time signatures.

Duration Allows you to specify a delay according to a note value (whole, half, quarter, eighth, or sixteenth note).

Groove Provides fine adjustment of the delay in percentages of a 1:4 subdivision of the beat.

This new version of Mod Delay II is provided in TDM, RTAS, and AudioSuite formats.



Mod Delay II plug-in

For more information on the features of the Mod Delay II plug-in and using it in Pro Tools, refer to the DigiRack Plug-Ins Guide.

POW-r Dither

The POW-r Dither plug-in is an advanced type of dither that provides optimized word length reduction. It is designed for final-stage critical mixdown and mastering tasks where the highest possible fidelity is desired when reducing bit depth.

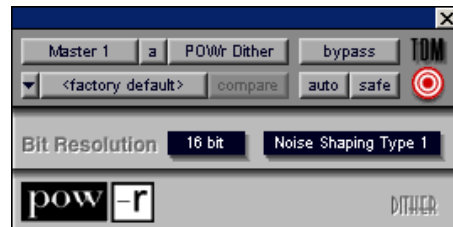

POW-r Dither plug-in

For more information on the features of the POW-r Dither plug-in and using it in Pro Tools, refer to the DigiRack Plug-Ins Guide.

D-Verb Plug-In

D-Verb is a studio-quality reverb provided in TDM, RTAS, and AudioSuite formats.



D-Verb plug-in

D-Verb has the following parameters and controls:

Output Meter Indicates the output level of the processed signal. For the stereo version of D-Verb, it represents the summed stereo output.

Clip Indicator Shows whether or not clipping has occurred.

Input Level Adjusts the input volume of the reverb to prevent the possibility of clipping and/or increase the level of the processed signal.

Wet/Dry Adjusts the balance between the dry signal and the effected signal, giving you control over the depth of the effect.

Algorithm Selects one of seven reverb algorithms: Hall, Church, Plate, Room 1, Room 2, Ambience, or Nonlinear.

Size Allows you to adjust the overall size of the reverberant space. There are three sizes: Small, Medium, and Large.

Diffusion Sets the degree to which initial echo density increases over time.

Decay Controls the rate at which the reverb decays after the original direct signal stops.

Pre-Delay Determines the amount of time that elapses between the original audio event and the onset of reverberation.

Hi Frequency Cut Controls the decay characteristic of the high frequency components of the reverb. It acts in conjunction with the Low-Pass Filter control to create the overall high frequency contour of the reverb.

Low-Pass Filter Controls the overall high frequency content of the reverb by allowing you to set the frequency above which a 6 dB per octave filter attenuates the processed signal.

 For more information on the features of the D-Verb plug-in and using it in Pro Tools, refer to the PDF version of the Digidesign Plug-Ins Guide.

TimeAdjuster Plug-In

TimeAdjuster for Pro Tools 5.3.1 provides a choice of three plug-ins:

Short Provides a maximum delay of 256 samples at all sample rates.

Medium Provides a maximum delay of 2048 samples at all sample rates.

Long Provides a maximum delay of 8192 samples at all sample rates.

 *For more information on the features of the TimeAdjuster plug-in and using it in Pro Tools, refer to the DigiRack Plug-Ins Guide.*

New HTDM Plug-In Format

Pro Tools 5.3.1 supports Digidesign's new HTDM (host TDM processing) plug-in format.

HTDM plug-ins combine the flexibility of TDM plug-ins with the power of RTAS plug-ins by using the processing power of your host computer, while allowing plug-in insertion on all track types, including disk tracks, auxiliary inputs, and master faders. This allows you to use a greater number of plug-ins in a session without restricting their usage on specific track types.

New Avid Inter-operability Support

Support for AVoption|XL, DigiTranslator, and Avid Unity MediaNet and MediaManager

Pro Tools 5.3.1 provides integrated support of AVoption|XL, DigiTranslator 2.0, and Avid Unity MediaNet and MediaManager 3.0 on Windows. These features provide Avid inter-operability, simplifying workflow between Pro Tools and other OMFI (Open Media Framework Interchange) applications.

AVoption|XL for Windows

(Pro Tools|HD on Windows XP Professional Edition Only)

Pro Tools|HD 5.3.1 supports AVoption|XL on Windows XP Professional Edition. AVoption|XL combines the powerful audio post production features of Pro Tools with integrated support for the import, capture, and playback of Avid video media.

AVoption|XL consists of software, a PCI card that you install in a Pro Tools|HD system, and an external I/O box that connects to the PCI card. The Digidesign audio hardware provides digital audio recording, editing, mixing, and processing. The Avid video hardware provides video capture and import, full-screen video playback on an external PAL or NTSC monitor, professional quality video compression, and the capability to record and play back uncompressed video.

 *For more information on AVoption|XL, refer to the Pro Tools AVoption|XL Guide.*

AVoption|XL Capabilities

AVoption|XL lets you:

- Import and capture multiple NTSC or PAL video clips to the Movie track.
- Play the Movie track with near sample-accurate precision against audio tracks in a Pro Tools session.
- Spot or Slip the video track to a new time code location, and spot audio to the video track.
- Spot individual video clips to new locations in the Movie track.
- View video edits and clip definitions in the Movie track.
- View the Movie track as a series of picture frames.
- Play video on an external NTSC or PAL monitor.

You can also:

- Import JFIF video media files from Meridian-based Avid systems, such as Media Composer or Symphony, into the Movie track of a Pro Tools session, while recording audio simultaneously.
- Capture JFIF format video media in the Movie track of a Pro Tools session.

FilmFrame

The FilmFrame option enables support for true 24P (Progressive Scan) picture media in AVoption|XL. Using FilmFrame, you can import and play back 24P material captured in Avid video workstations.

When using FilmFrame, all clips in the Movie track should be 24P. This is because the first frame in the Movie track sets the video engine to the appropriate speed. If the first clip is 24 fps, the entire Movie track will play at 24 fps. This will effect the playback speed of any subsequent clips of different fps speeds.

 *For information on FilmFrame workflows, see the AVoption|XL Guide.*

24P Avid Video Playback Capability

AVoption|XL plays back 24P format video files imported from Avid editing systems. (24P indicates 24 frames per second using progressive image storage, as opposed to interlaced fields.) 24P files may be played and edited, just like video clips in other formats, but they cannot be recorded directly to the Pro Tools Timeline.

To play back 24P format video files, you will need:

- AVoption|XL
- Pro Tools 5.3.1 software
- FilmFrame

Converting Sessions from 24 FPS to 29.97 FPS

When changing a session frame rate from 24 to 29.97, or when importing a track from a 24 fps session to a 29.97 fps session, you must enable audio pull down in the 29.97 fps session for the files to import to the correct time.

Conversely, for a 29.97 track or session to translate correctly to a 24 fps session, it has to have been edited with audio pulled down. The 24 fps session should not be pulled down.

Support for DigiTranslator, and Avid Unity MediaNet and MediaManager

Pro Tools 5.3.1 includes Windows support for DigiTranslator 2.0. DigiTranslator enables you to exchange audio files, video files, and OMF sequences between OMFI-compatible applications and Pro Tools. Pro Tools 5.3.1 also includes Windows support for Avid Unity MediaNet and MediaManager 3.0 with AVoption|XL, providing Avid inter-operability between Pro Tools and other OMFI applications on Avid Unity.

 *DigiTranslator is supported with Pro Tools|HD, Pro Tools|24 MIX, and Pro Tools LE systems on Windows. However, AVoption|XL and MediaManager are only supported with Pro Tools|HD systems on Windows.*

Compatibility and Avid MediaManager

Pro Tools 5.3.1 supports Avid Unity MediaNet and MediaManager 3.0. MediaManager supports files of any sample rate. However, Avid workstations do not. To ensure compatibility with Avid workstations, Pro Tools with the DigiTranslator option provides the Enforce Avid Compatibility setting, which limits session sample rates to 44.1 and 48 kHz.

 *For more information on the DigiTranslator option and MediaManager, see the DigiTranslator Integrated Option Guide.*

MachineControl Update

With Pro Tools 5.3.1 and the MachineControl option, you can control video transports operating at 24 fps.

Remote 9-Pin Deck Emulation Mode

Track arming and transport functions on Pro Tools TDM systems with the MachineControl option can be remotely controlled by devices that support Sony P2 9-pin serial commands. This allows properly equipped workstations, mixing consoles, or synchronizers to slave a Pro Tools system to other transports. The Pro Tools Transport slaves to Sony P2 9-pin serial commands when set to Transport = Remote. This allows you to temporarily toggle remote control of Pro Tools on or off when necessary.

 *For a current list of supported controllers, see the Digidesign Web site at:*

www.digidesign.com

To respond to 9-pin commands, the appropriate connections must be made using a cable equipped with a female D-SUB-9 connector and a male Mini-DIN-8 connector. You must use the computer's serial port, and not the serial port on any Pro Tools card (DigiSerial Port). If your computer does not have a serial port, use a Stealth Serial Adapter or Keyspan 28x Adapter.

 *For information on the cables used for different MachineControl configurations, see the MachineControl Guide.*

Voice Load Balancing and PCI Optimization

Voice Load Balancing is implemented to allow the PCI load to be balanced when running sessions with larger numbers of voices, edits and crossfades. Splitting the voices between DSPs helps manage the amount of PCI bus traffic.

Although manual voice assignment is still possible, the auto-assignment algorithm has been changed to balance the load between DSPs. For example, if 24 voices are being used and all have been automatically assigned, there will be 12 voices per DSP. This auto-assign algorithm will also take into account other load factors on the DSP such as manually assigned tracks or plug-in usage.

With Pro Tools|HD 2 and 3, and Pro Tools|24 MIXplus and MIX³ systems, Pro Tools 5.3.1 further improves PCI Bus performance by placing the second 32-voice Playback Engine on the first HD Process or MIX Farm card instead of on the HD Core or MIX Core card.

WAV Now BWF

Pro Tools can read and play any standard WAV format files. However, it saves files exclusively in the Broadcast Wave Format (BWF). BWF has the same file name extension as WAV files (.wav). BWF files store time stamp information in a consistent way that makes them ideal for interchange operations.

QuickTime Playback

Pro Tools 5.3.1 supports playback of QuickTime files on Windows. QuickTime is digital video technology designed to produce compact video files for multimedia use. Supported QuickTime formats include: MPEG, AVI, MOV, and DV.

⚠ *You must install the version of QuickTime provided on the Pro Tools CD-ROM if you want to use QuickTime playback in Pro Tools on Windows. Be sure to install the "Recommended" install of QuickTime or Pro Tools will not handle QuickTime video correctly.*

Using QuickTime Movies in Pro Tools

Pro Tools allows you to import QuickTime movies into your Pro Tools sessions.

Once imported into Pro Tools, a QuickTime movie is displayed in its own Movie track in the Edit window, and in a floating Movie window. With a QuickTime movie in the session, Pro Tools serves as an ideal random-access visual reference for "sweetening" the movie by adding sound effects, music, foley, dialog, or other audio.

Pro Tools provides precise, frame-accurate audio and video synchronization. This means you can use your Pro Tools system as an off-line audio editing system, leaving the video editing suite free for video editing.

⚠ *On Pro Tools systems with two monitors, the QuickTime Movie window is only supported on the first monitor.*

With Pro Tools, you can:

- ◆ Import a QuickTime movie into a session.
- ◆ Synchronize audio events to a QuickTime movie, using the Pro Tools editing features to spot and nudge regions to video frames.
- ◆ Scrub audio elements in tandem with a QuickTime Movie window.
- ◆ Bounce to a new QuickTime movie (MOV format only).

 *For more information on using QuickTime Movies in Pro Tools, refer to the Pro Tools Reference Guide.*

24-Bit Sessions on IDE Drives

Pro Tools TDM 5.3.1 provides support for up to 32-track, 24-bit, 48 kHz performance from one dedicated internal IDE/ATA audio drive on Pro Tools|HD, Pro Tools|24 MIX, and Pro Tools|24 systems. On Pro Tools|HD systems, the supported track counts will be reduced at higher sample rates.

 *For the latest hard drive compatibility information, see the Digidesign Web site at:*

www.digidesign.com

Minimum Drive Requirements

- Disk drive rotational speed: 7200 RPM or faster
- Average seek time of less than 10.0 ms
- Support of the UDMA66 controller
- Drive must be dedicated for audio

 *Audio tracks are not supported on the operating system drive.*

- Drives should be formatted with Windows Disk Manager as NTFS or FAT32.

 *For optimal disk priming, set the cluster size to 32k using Windows Disk Manager or Partition Magic.*

Drive Space Required

- Mono, 16-bit, 44.1 kHz audio requires approximately 5 MB/minute disk space.
- Mono, 24-bit, 44.1 kHz audio requires approximately 7.5 MB/minute disk space.

chapter 5

Corrections to the 5.3 Guides

This chapter lists corrections to the Pro Tools 5.3 guides, and also documents some items not covered in those guides.

Pro Tools 5.3 Reference Guide

PN 932709360-00 REV A 01/02

Routing a Pro Tools Output Pair to Multiple Audio Interface Output Ports

On pages 42 and 64 of the *5.3 Reference Guide*, the fifth step for selecting multiple output ports for a Pro Tools output channel pair incorrectly states: “Control+Shift an additional output destination.”

Correction:

The fifth step for selecting multiple output ports for a Pro Tools output channel pair should say: “Control-click (Macintosh) or Start-click (Windows) an additional output destination.”

In addition, you must hold down the modifier key (Control on Macintosh, or Start on Windows) before clicking on the Output menu.

Latch Record Enable Buttons

On page 52 of the *5.3 Reference Guide*, the Latch Record Enable Buttons section does not specify the track type when it states that: “When deselected, prevents multiple tracks from being record enabled: Record-enabling a track takes any other track out of record-enabled mode.”

Correction:

The Latch Record Enable buttons are for audio tracks only.

Latch Record Mode

On page 119 of the *5.3 Reference Guide*, the Latch Record Mode section fails to specify the track type when it states that “you can record enable additional tracks.”

Correction:

Latch Record mode is for audio tracks only.

Allocating Audio Drives

On page 124 of the *5.3 Reference Guide*, the second step for allocating audio drives in your system incorrectly says to assign a hard drive for each track by “clicking in the Record Location column.”

Correction:

The second step for allocating audio drives in your system should say: “In the Disk Allocation dialog, to assign a hard drive for each track, click in the Root Media Folder column and select a hard drive (or folder) for the track.”

Recording to MIDI Tracks

On pages 154–155 of the *5.3 Reference Guide*, the second step for recording one or more MIDI tracks incorrectly states: “Record enable any MIDI tracks to which you want to record by clicking their Record Enable buttons.”

Correction:

The second step for recording one or more MIDI tracks should say: “Record enable the MIDI track to which you want to record by clicking on its Record Enable button. To record enable multiple MIDI tracks, Shift-click the Record Enable buttons on each track.”

Editing While Audio Tracks Loop or Play

On page 169 of the *5.3 Reference Guide*, the list of edits that can be performed while audio tracks loop or play incorrectly includes “Add fades or crossfades to audio regions.”

Correction:

Creating fades or crossfades during playback stops the playback.

Striping from Silence Regions

On page 257 of the *5.3 Reference Guide*, Minimum Strip Duration incorrectly states that the range of the Minimum Strip Duration parameter is 0–10,000 ms.

Correction:

The range of the Minimum Strip Duration parameter is 0–4,000 ms.

MIDI Track Offset

On page 313 of the *5.3 Reference Guide*, the second paragraph of the second step for configuring a MIDI track offset incorrectly states that the value displayed in the Msec Offset column is updated “when a new value is entered in the SMPTE Offset column.”

Correction:

The second step for configuring a MIDI track offset should say that the value displayed in the Msec Offset column is updated “when a new value is entered in the Sample Offset column.”

External Clock Sources

Page 475 of the *5.3 Reference Guide* incorrectly states that the base rate for external clock source “equals 44.1 kHz for 88.2 and 174.4 kHz.”

Correction:

The base rate for external clock source “equals 44.1 kHz for 88.2 and 176.4 kHz.”

Spotting Movie to Sync Point

On page 505 of the 5.3 *Reference Guide*, the fourth step for spotting the movie to a sync point incorrectly says to “Set the Grid Value to Feet.Frames.”

Also on page 505, steps 8 and 9 refer to the “Move Region To dialog.”

Correction:

The fourth step for spotting the movie to a sync point should say “Set the Grid Value to Time Code.”

Steps 8 and 9 should refer to the “Spot dialog,” not the Move Region To dialog.

Enhancing Performance by Clearing the Undo Queue

Page 180 of the *Reference Guide* describes Multiple Undo. While this section correctly lists actions which clear the Undo queue, the following tip for improved system performance was omitted:

Correction

 *Clearing the Undo queue can speed up system response by reducing the load on your CPU memory caused by maintaining multiple levels of Undo.*

Additions to the Pro Tools 5.3 Reference Guide

Pro Tools 5.0.1 (or Earlier Sessions) and Offline Regions

Offline Regions (a feature which debuted in Pro Tools software version 5.1) is not available when opening sessions created in Pro Tools 5.0.1 or earlier. When opening Pro Tools 5.0.1

or earlier sessions (including Pro Tools Free sessions), skipped audio files will not come up as blue “off-line” regions. Instead, they will be dropped.

Mono Sub-Path Names Now Based on the Name of Their Stereo or Multichannel Main Path

Mono sub-paths are now automatically named (or appended), based on the name of their stereo or multichannel main path. For example, stereo path “nameX” will produce sub-paths “nameX1,” “nameX2,” and so on. If a stereo path is renamed, its sub-paths will also be renamed.

Auditioning at 176.4 or 192 kHz

Auditioning regions in the Regions List and previewing crossfades and AudioSuite processes use Direct I/O for output routing. The output path is defined using the Audition Path setting in the I/O Setup dialog.

With sessions at 176.4 or 192 kHz, Direct I/O is limited to the first six physical outputs. Audition Path outputs 7 and higher are not available, and are grayed out. Additionally, if you haven’t defined an Audition Path in I/O Setup, the Audition Path defaults to outputs 1–2. (Note that previously when using Pro Tools 5.3 on Macintosh with 176.4/192 kHz sessions, the Audition Path outputs erroneously defaulted to outputs 7–8 when outputs 1–6 were in use by a main Output path.)

Table 2. Session lengths, based on session sample rates

Session Sample Rate	Maximum Session Length
44.1 kHz	12 hours and 24 minutes
48 kHz	11 hours and 24 minutes
88.2 kHz	6 hours and 52 minutes
96 kHz	5 hours and 52 minutes
176.4 kHz	3 hours and 21 minutes
192 kHz	2 hours and 21 minutes

Upsampling and Session Length

Upsampling a lengthy session with the Save Session Copy In command can result in the loss of region data beyond the session end point. This is because sessions with higher sample rates have shorter maximum durations (see Table 2).

Tip for Cutting (or Copying) and Pasting Right Pan Automation Data

After cutting Right Pan automation data, the cut automation data can only be pasted to another right side of a stereo track, unless you hold down the Control key. Hold down the Control key whenever pasting different automation types.

Tip for Improving Performance

Pro Tools performance is affected by the number of levels of Undo defined. To ensure optimized Pro Tools performance, set the Levels of Undo to the lowest acceptable value for you in the Editing pane of the Pro Tools Preference dialog. This can be especially helpful when performing edits involving large numbers of regions (for example, more than a few thousand).

Tip for Creating New Fades

To save time (up to two times faster) when creating new fades using the Batch Fades dialog, disable the Adjust Existing Fades checkbox.

Creating Fades on a Region Abutted to a Second Region

When attempting to create a Fade In or Fade Out on a region abutted to a second region, the Crossfade dialog appears instead of the Fade In or Fade Out dialog. In these instances, use the Smart Tool to create a Fade In or Fade Out, or use the Fade to Head and Fade to Tail commands.

Getting Started with HD Guide

PN 932709429-00 REV A 01/02

Windows System Requirements

On page 4 of the *Getting Started with HD Guide*, the system requirements for Windows says: “Windows XP Home Edition, or Windows 2000 Professional Edition with Service Pack 2 or higher.”

Correction:

Pro Tools|HD 5.3.1 does not support Windows 2000. The system requirements for Windows should say “Windows XP Home Edition or Professional Edition.”

 *If you are changing operating systems, Digidesign recommends a clean install of Windows on a newly formatted drive or partition rather than upgrading the operating system.*

Windows Hard Drive Requirements

On page 5 of the *Getting Started with HD Guide*, the tip for hard drive requirements for Windows says: “Drives formatted as FAT32 are recommended for quicker disk priming time when starting a Pro Tools record operation.”

Correction:

Drives can be formatted either NTFS or FAT32. The tip for hard drive requirements for Windows should be ignored.

Connecting Digidesign Legacy I/O

On pages 15 and 35 of the *Getting Started with HD Guide*, an important recommendation is missing after the steps for connecting Digidesign Legacy I/Os (such as 888|24 I/O or 882|20 I/O).

Correction:

The following tip should come after step 2 for connecting Digidesign Legacy I/Os:

 *In order to ensure the proper functioning of legacy audio interfaces (such as 888|24 I/O or 882|20 I/O), it is recommend that you launch Pro Tools and declare the legacy audio interfaces in the Hardware Setup dialog prior to powering on your legacy audio interfaces. Then quit Pro Tools, shut down your computer, power on your audio interfaces and turn on your computer.*

Routing a Pro Tools Output Pair to Multiple Audio Interface Output Ports

On pages 27 and 50 of the *Getting Started with HD Guide*, the fifth step for selecting multiple output ports for a Pro Tools output channel pair incorrectly states: “Control+Shift an additional output destination.”

Correction:

The fifth step for selecting multiple output ports for a Pro Tools output channel pair should say: “Control-click (Macintosh) or Start-click (Windows) an additional output destination.”

Windows Configuration

Chapter 3, “Windows Configuration,” in the *Getting Started with HD Guide*, is incorrect.

Correction:

Refer to Chapter 2, “Installing and Configuring Pro Tools|HD” in this addendum for the corrected version of Chapter 3, “Windows Configuration,” from the *Getting Started with HD Guide*.

192 Digital I/O Guide

PN 910610233-00 REV A 01/02

Loop Master LED

On page 3 of the *192 Digital I/O Guide*, the section titled Loop Master LED incorrectly states that, “Loop Master will always be lit with a single interface.”

Corrections:

The section titled Loop Master LED should say that, “Loop Master will always be lit with a single 192 Digital I/O, unless a SYNC I/O is connected.”

192 I/O Guide

PN 932709286-00 REV A 01/02

192 I/O Features

On page 1 of the *192 I/O Guide*, the 192 I/O incorrectly states that the 192 I/O supports “ten channels of 24-bit-supported AES/EBU I/O, eight channels of which support sampling rates of up to 192 kHz,” and “two 24-bit-capable S/PDIF I/O supporting sample rates of up to 96 kHz.”

Corrections:

The 192 I/O supports “eight channels of AES/EBU I/O (four channels at 192 kHz),” and “two additional channels of AES/EBU or S/PDIF (up to 96 kHz).”

Loop Master LED

On page 3 of the *192 I/O Guide*, the section titled Loop Master LED incorrectly states that, “Loop Master will always be lit with a single interface.”

Corrections:

The section titled Loop Master LED should say that, “Loop Master will always be lit with a single 192 I/O, unless a SYNC I/O is connected.”

Output Trims

On page 6 of the *192 I/O Guide*, the second paragraph of the section titled Output Trims incorrectly states that you can, “match two different headroom values for either input connector.”

Corrections:

The second paragraph of the section titled Output Trims should say that you can, “match two different headroom values for either output connector.”

96 I/O Guide

PN 932709282-00 REV A 01/02

Loop Master LED

On page 3 of the *96 I/O Guide*, the section titled Loop Master LED incorrectly states that, “Loop Master will always be lit with a single interface, regardless of synchronization mode.”

Corrections:

The section titled Loop Master LED should say that, “Loop Master will always be lit with a single interface 96 I/O, unless a SYNC I/O is connected.”

SYNC I/O Guide

PN 910609328-00 REV A 01/02 and
PN 910609328-00 REV B 06/02

LTC Servo Gain

On page 54 of the *SYNC I/O Guide* (Rev A and B), the default setting and the number of available options are incorrect.

Corrections:

- ◆ The default LTC Servo Gain setting is 0000 (not -001) when accessing Servo Gain through the front panel controls. In Pro Tools, the default setting is listed as “LTC (0).”
- ◆ There are five Servo Gain settings.

Generating Time Code and Pull Rate Settings

On page 41 of the *SYNC I/O Guide* (Rev A only), the Generating and Regenerating Time Code section omitted information regarding Pull Up and Pull Down settings.

Correction:

- Time code generated by the SYNC I/O does not follow session Pull Up and Pull Down settings.

VSO Range

On page 35 of the *SYNC I/O Guide* (Rev A only), the table listing effective sample rate ranges for VSO (Variable Speed Override) contains incorrect minimum and maximum VSO rates.

Correction:

Effective VSO rates

Sample Rate (kHz)	Rate Type	Min (kHz)	Max (kHz)
44.1	1x	40000	50500
48			
88.2	2x	80000	101000
96			
176.4	4x	160000	202000
192			

AVoption|XL Guide

PN 932708445-00 REV A 06/02

Installing AVoption|XL

The installation procedure for installing AVoption|XL on Windows XP is incorrect and incomplete as listed in the *Pro Tools AVoption|XL Guide*.

Correction:

To install AVoption|XL on Windows XP:

- 1 Install your Pro Tools software and hardware according to the installation instructions in your *Getting Started Guide* or your current *Pro Tools Addendum*. Confirm Pro Tools is functioning correctly.
- 2 Install AVoption|XL hardware by following the Pro Tools AVoption|XL Guide, as listed in the “Installing AVoption|XL Hardware” section.

 *Do not install AVoption|XL software before installing AVoption|XL hardware.*
- 3 Turn on your computer.
- 4 Start up Windows, logging in with Administrator privileges. If you do not have Administrator privileges or do not know how to set them up, see your *Windows User's Guide*.
- 5 Wait for the Found New Hardware Wizard dialog to appear and leave it open.
- 6 Leaving the Found New Hardware Wizard dialog open, place the AVoption|XL Installer CD-ROM in your CD-ROM drive. Locate and double-click the Setup icon.
- 7 Click Next.
- 8 Click Yes.

- 9 Wait for the installer to finish installing all software components. When installation is complete, click Finish to restart your computer.

Slot Configurations for AVoption|XL

On pages 41 and 43 of the AVoption|XL Guide, the slot order for the Avid Digital Video Board and FibreChannel card in an IBM M Pro 6850 and a Compaq Evo W8000 is reversed.

Correction:

The Avid Digital Video Board should be placed in CPU Slot 2 and the FibreChannel card (Unity systems only) should be placed in CPU Slot 3.

Expanded Systems Guide

PN 932109431-00 REV A 1/02

Supported Chassis

Some illustrations show examples of Pro Tools|HD systems being installed in certain expansion chassis. This does not guarantee that those chassis have been qualified for Pro Tools|HD systems. Always check for the latest compatibility information at:

www.digidesign.com

ProControl Guide

PN 932709087-00 REV A 03/01

F-Key Switches

On page 56 of the *ProControl Guide*, the section titled F-Key Switches lists the assignments of the F2 and F3 Function switches. The ProControl F2 and F3 keys have new functions with Pro Tools 5.3.1 on Macintosh and Pro Tools 5.3.3 on Windows for two new PRE features: Channel-Wide Gain Control, and Individual Channel Mode.

Correction:

F2 Toggles between control of Mic Preamp channels for PRE and insert focus for the main unit's DSP Edit/Assign Section.

 *In older Pro Tools versions, the F2 F-Key switch was used to display which Pro Tools channel strips had active plug-ins assigned to them. With Pro Tools 5.3.1 on Macintosh and Pro Tools 5.3.3 on Windows and higher, this operation is accomplished by pressing OPT(ALT)ALL+F2.*

F3 Enables Channel-Wide Gain Control mode for PRE.

 *In older Pro Tools versions, the F3 F-Key switch toggled between "Fixed" and "Velocity sensitive" modes for the DSP edit assign encoders. As of Pro Tools 5.3.1 on Macintosh and Pro Tools 5.3.3 on Windows, this operation is accomplished by pressing OPT(ALT)ALL+F3.*

Overview of Plug-Ins

On page 137 of the *ProControl Guide*, the steps for toggling the DSP/Edit Assign knobs between fixed and velocity sensitive modes are incorrect as of Pro Tools 5.3.1 on Macintosh and Pro Tools 5.3.3 on Windows.

Correction:

To toggle the DSP Edit/Assign knobs between fixed and velocity sensitive modes:

- 1 Press OPT(ALT)ALL+F3.
- 2 Press OPT(ALT)ALL+F3 again to toggle back.

 *In versions of Pro Tools prior to Pro Tools 5.3.1 on Macintosh and Pro Tools 5.3.3 on Windows, press the F3 F-Key switch to toggle between "Fixed" and "Velocity sensitive" modes for the DSP edit assign encoders.*

Control|24 Guide

PN 932709088-00 REV A 03/01

Headphone Jack and Controls

On page 37 of the *Control|24 Guide*, the section titled Headphone Jack and Controls incorrectly states that, "the jack is located on the lower-left of the Control Room Monitor section."

Correction:

The section titled Headphone Jack and Controls should say that, "the jack is located on the lower-right of the Control Room Monitor section."

Contrast Mode Pages

On page 143 of the *Control|24 Guide*, the sections titled Prefs Pages and Contrast Mode Page are incorrect.

Correction:

The sections for Prefs Pages and Contrast Mode Page should be ignored because these pages are not available on the Control|24.

PRE Guide

PN 910609434-00 REV A 06/02

Mic Inputs 1–8

On page 10 of the *PRE Guide*, in the section titled Mic Inputs 1–8, the wiring scheme described in the first sentence is incorrect.

Correction:

The first sentence in the section titled Mic Inputs 1–8 should read: “These are balanced XLR jacks, with Pin 1 wired ground, Pin 2 wired hot (or “+”), and Pin 3 wired cold (or “–”).”

Key Commands

The following corrections are for the *Pro Tools Keyboard Shortcuts for Windows Systems*:

Key command	Error	Correction
Trim left edge of region to right/left by Nudge value	Alt-Start +/-	Alt +/-
Trim right edge of region to right/left by Nudge value	Ctrl-Start +/-	Ctrl +/-
Bypass Plug-in Insert	Alt-click on insert name in Inserts view	Ctrl-click on insert name in Inserts view
Send mute	Alt-click on send name in Sends view	Ctrl-click on send name in Sends view

